

SPECIFICATION FOR THE 8000 SERIES ROGOWSKI COIL TRANSDUCERS

FEATURES

- { Battery-powered coil/integrator combination
- { Flexible Rogowski coils can be fitted without 'breaking' the conductor.
- { Coil lengths up to at least 5m.
- { Thin-coil option uses a coil with only 6mm cross-sectional diameter.
- { Very long battery life - up to 12 months with a single PP3 battery
- { Can measure up to hundreds of kA.
- { Available in either single-sensitivity or three-sensitivity versions.
- { Sensitivity can be specified by the user.
- { Standard frequency response flat up to 2.5kHz.
- { Enhanced frequency response at the expense of a higher battery drain.
- { Low frequency response down to 2Hz (-3dB point)
- { Withstands very large overloads for an indefinite time.

1. INTRODUCTION

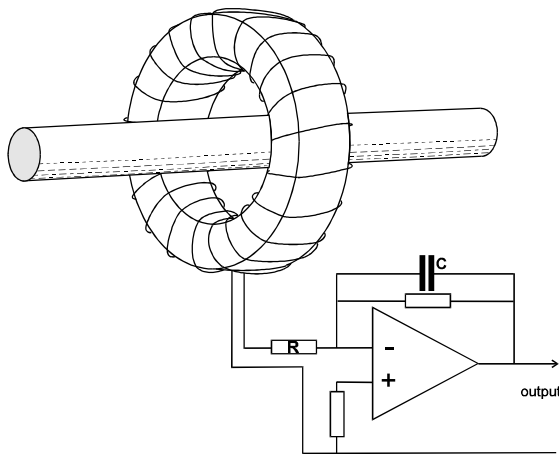

The **Rocoil**[®] 8000 series transducers comprise a complete current-measuring transducer in which a flexible Rogowski coil is permanently attached to the integrator. The output from the integrator is a voltage waveform that reproduces the current waveform. The transducer will accurately reproduce complex waveforms containing frequency components up to the 40th harmonic of power frequency.

A special feature of the 8000 is its exceptionally low power consumption. With a quiescent consumption of less than 50 μ A, it can operate for up to 1 year continuous service from a single alkaline PP3 battery.

2. THE ROGOWSKI COIL PRINCIPLE

The coil is an 'air cored' toroidal winding placed round the conductor such that the alternating magnetic field produced by the current induces a voltage in the coil. The coil is effectively a mutual inductor coupled to the conductor being measured and the voltage output direct from the coil is proportional to the rate of change of current. The special design of the coil ensures that its output is not influenced significantly if the conductor is positioned 'off-centre'. The design also ensures that the influence from currents and magnetic fields external to the coil is minimal.

To complete the transducer the coil output voltage is integrated electronically to provide an output that reproduces the current waveform. This combination of coil and integrator provides a system where the output is independent of frequency, which has an accurate phase response and which can measure complex current waveforms. By varying the integration parameters (C and R) the sensitivity of the complete measuring system, measured in Amperes per Volt, can be varied over about five orders of magnitude. The output from the integrator can be used with any form of electronic indicating device such as a voltmeter, oscilloscope, protection system or metering equipment

3. COIL SENSOR (Rogowski Coil)

Description: The flexible Rogowski coil in the 8000 can be used for measuring electric current in large or awkwardly-shaped conductors, where space round the conductor is limited, and for measuring very large currents.

Installation: The coil is fitted by wrapping it round the conductor to be measured and bringing the ends together. The ends are fitted with a clip to ensure that they are aligned correctly. Although the clip is designed to provide an accurate location of the ends, Rogowski coils are actually much less sensitive to misalignment of the ends than are current transformers.

Electrical connection to the coil is at one end only. The other end is 'free' to be threaded round awkwardly-shaped conductors or conductors in confined spaces.

It is not necessary to mount the coil so that it is circular nor is it necessary to have the conductor exactly in the centre of the loop. Off-centre operation does not normally introduce errors of more than 1 - 2%. If the coil is long enough it can be wrapped more than once round the conductor provided the ends are brought together correctly. The output is proportional to the number of wraps. If several coils are being used they should be mounted in the same sense (i.e. with all the output leads coming off all clockwise or all anti-clockwise) and the outputs will then be in phase.

Insulation: Coils can be insulated with a single layer of polyolefin having a thickness of about 0.4mm. This provides only a limited amount of electrical insulation and these coils are not considered suitable for use on uninsulated conductors carrying dangerous voltages

A better insulated version is available which has a second insulating layer giving an additional 1mm thickness of insulation. Additional insulation makes the coil less flexible but it is tougher and less susceptible to abrasion. This version is the one usually provided.

Dimensions:

Length: The standard coil length is 500mm but lengths from 330mm to several metres are available.

Cross - Section: The standard coil has a maximum diameter of 13mm at the 'free' end. The main body of the coil has a diameter of about 8.5mm. For the coil with double insulation the body diameter is about 10.5mm. Recently a thinner coil has been introduced which has a cross-sectional diameter of about 6mm. The 'Type 4022' version of this coil has a simplified end joining method with a small diameter free end and is useful where there is limited access round the conductor.

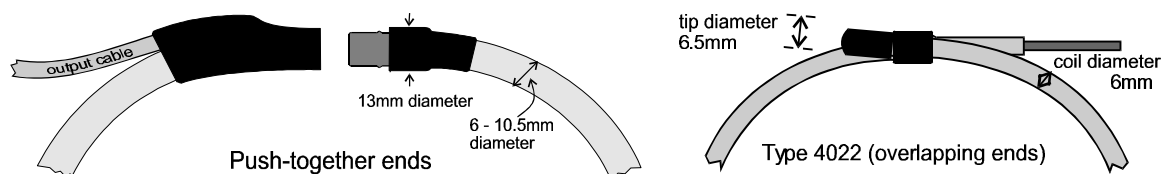

Cable Length Coil to Integrator: Standard length is 2m

4. INTEGRATOR

Description: The integrator for the 8000 is enclosed in a black plastic case, dimensions 103 x 62 x 23mm. The coil is connected via a permanently attached cable. The integrator is available in a single-range version and a switched three-range version. Output is via a BNC connector. For the single-range version the connections and the switch are at one end so that the integrator can be used when it is carried in a coat pocket.

Power Supply: The integrator is powered from a single PP3 battery. The quiescent power consumption is less than 50 μ A. For an alkaline battery with a capacity of 500mAh the lifetime is in

excess of 1 year. Because of the exceptionally long battery life it is important to remember to check the battery voltage periodically.

NOTE: The power consumption refers to quiescent operation, i.e. with no current being measured. The consumption will increase when measurements are being made. However at 50Hz the effect is negligible. Rated current at 50Hz adds about 1 μ A to the consumption. Prolonged use at high frequencies and high current amplitudes will increase the consumption. For example, measuring rated current at 500Hz roughly doubles the battery drain.

5 TRANSDUCER PERFORMANCE

Output Voltage (AC Output): 1V output for the nominal sensitivity. The sensitivity value, i.e. the current to give 1V output, can be chosen by the customer. The most sensitive range is normally 50A = 1V (100A/V for a thin coil) but it may be possible to provide more sensitive ranges by special arrangement.

Overload Capability: The output is linear up to a peak of at least 3 x the nominal sensitivity. For example at 1000A/V sensitivity the output is accurate up to at least 3000A peak (2000A rms for a sine wave). At high frequencies the overload capacity is diminished. Very large overloads will not damage the transducer.

Noise: Typically less than 1mV peak to peak referred to the output. For example at 1000A/V, the noise is equivalent to less than 1A p/p.

Output Impedance: 51 Ω . For best accuracy the integrator should be used with high-impedance recording/monitoring equipment having an input impedance preferably greater than 50k Ω .

Measurement Accuracy: $\pm 1\%$

Effect of Coil Temperature on Accuracy: For a 500mm coil the output is reduced by 0.03% / $^{\circ}$ C. For longer coils the temperature effect is larger (roughly proportional to coil length).

Frequency Response: Stated accuracy applies in the range 20Hz to 2kHz. The higher frequency components in the output should not exceed the nominal sensitivity.

Low frequency -3dB point: less than 2Hz.

Phase error at 50Hz: 2 $^{\circ}$. Unlike a split current transformer the phase error is not affected by misalignment of the coil ends. It can be relied upon to have the same value each time the transducer is used.

Battery Life vs. Frequency Response. Units are available having an enhanced frequency response but with reduced battery life as follows:

Upper frequency limit 4kHz: battery life 6 months continuous use

Upper frequency limit 8kHz: battery life 3 months continuous use

6) ORDERING INFORMATION:

To specify a transducer it is necessary to know:

- i) Whether it is a three-range version (8132), or single range (8112)
- ii) The sensitivity value(s) required.
- iii) The length of the coil.
- iv) The type of coil: (standard diameter with push together ends, thin cross-section with push-together ends, or type 4022).
- v) Battery life: (12 months, 6 months, or 3 months).