

Wiper Motor Wiring (Austin Mini) 2 Speed + Self Park

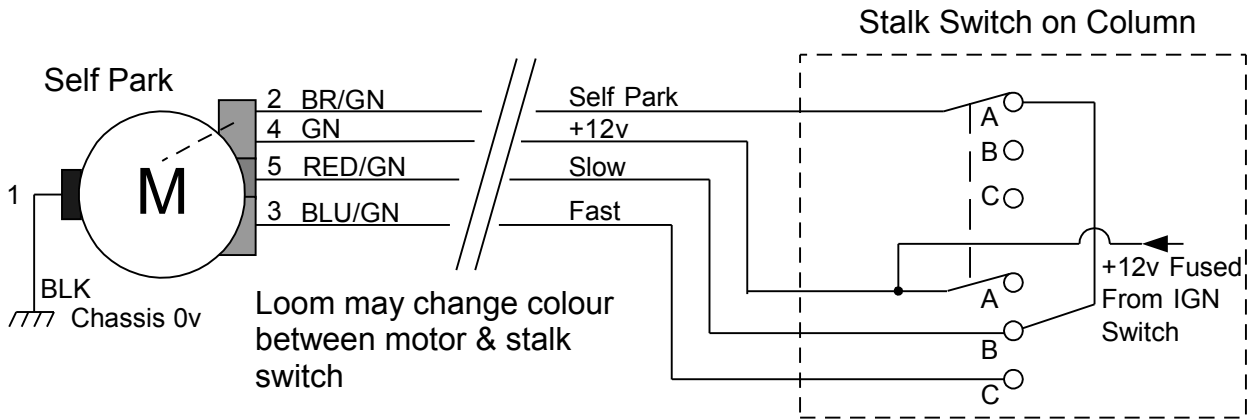

Switch shown in "off" (wipers parked) position

Internals of self park switch (shown in parked position)

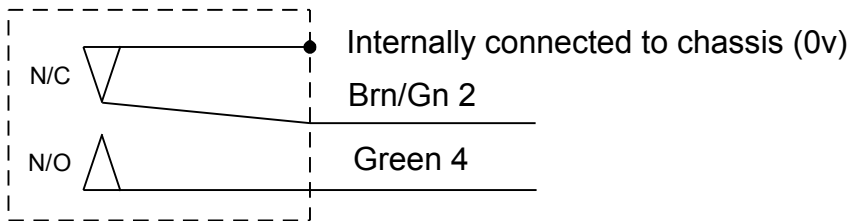

As can be seen, the internal self park switch is effectively a single pole changeover switch when moved by cam to parked position motor is effectively shorted to chassis to provide dynamic braking

Motor Multi Plug Wiring Detail

Rear view of plug i.e. As wires enter plug orientation is:-

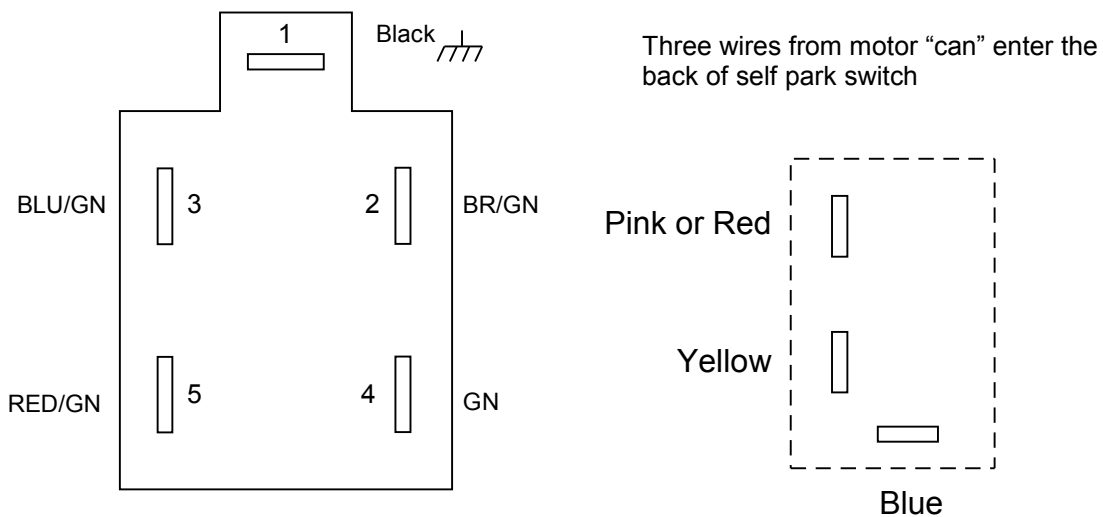

To incorporate an electronic interval wipe system (and "wash/wipe" if required) see the following page for circuit diagram and how this is incorporated into the standard circuit shown above.

Interval Wipe Circuit (Variable From Approx 2-20 Seconds)

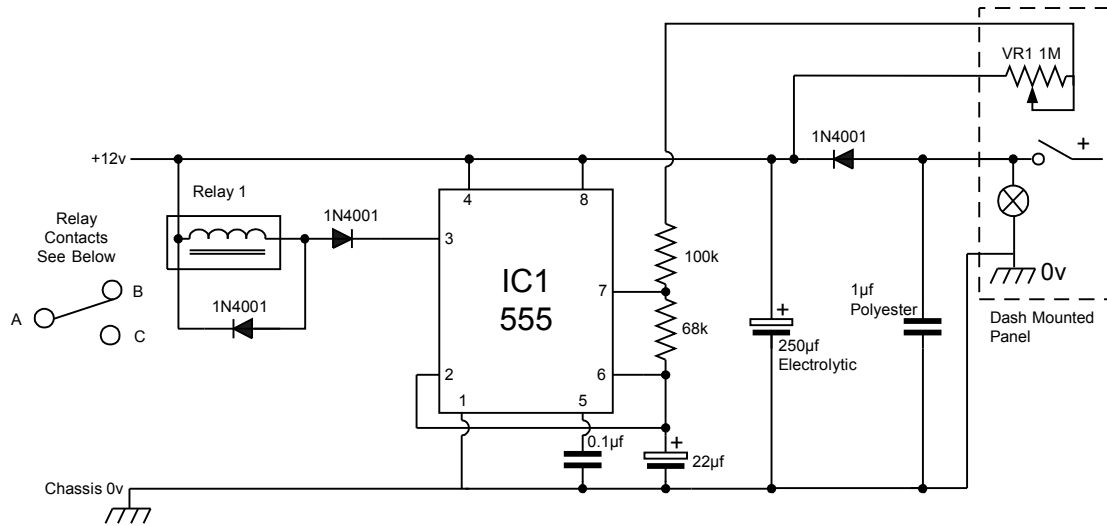

Wiring into Existing Circuit As on Page 1

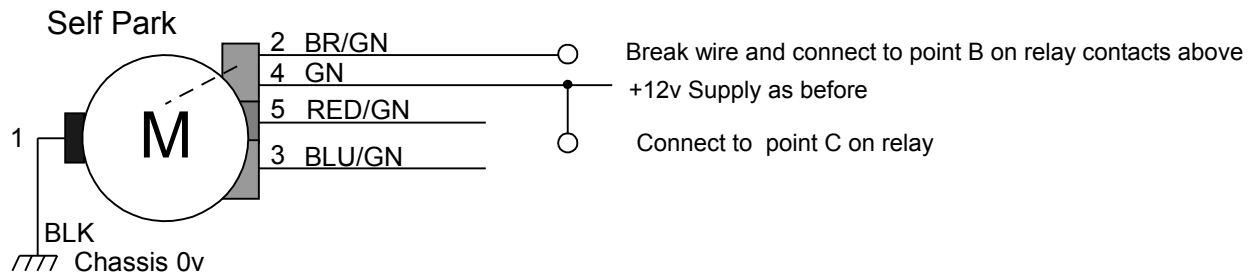

Point A of the relay switch contacts connects to the point on the stalk switch where the brown/green wire was connected.

N.B. Ensure relay contacts are rated at least 8 amps

I have also built a wash/wipe circuit into the system which activates the wipers for about 5 seconds each time the washer button is pushed momentarily. Plus I have incorporated a 'one shot' single wipe button. I got carried away once I started. Crazy really 'cos I only use the wipers if I accidentally get caught in the rain!!!

If you want the wash/wipe and one shot circuits let me know and I will draw them up

Please feel free to telephone/e-mail me if you need help

Tim Mackey 01492 534260
 07855 35229
 timmackey@hotmail.com