

# Homemade Puzzles

## Glass Maze plans

The object of this puzzle is to put the ball bearing in the front middle hole, find a way through the maze, and out of the back middle hole. These plans show how to construct the puzzle, with a route through.

The puzzle is made from the transparent covers of old CD cases: the type of plastic that is fairly brittle, because plastic model cement is the ideal adhesive to hold it together. Superglue may do the job, but I've found that superglue is not as good as it's made out to be. The thickness of this plastic is just about 1mm.

The size of the cube depends on the size of the ball bearing, this one is based on a 9.5 mm diameter ball bearing. All the dimensions shown here are in millimetres. All passable holes are shown in solid lines, all non-passable holes are shown in dotted lines.



Cut four pieces at 57mm x 58mm, and drill these 9 mm holes:

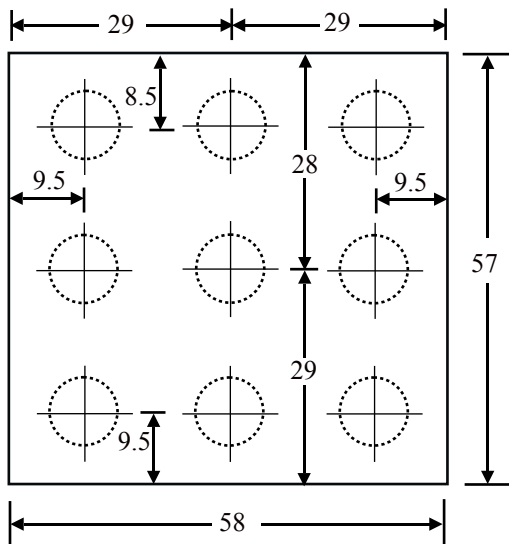

Cut six pieces at 56mm x 56mm: Drill these 9mm holes in each piece. The holes should be too small for the ball to pass through. In two of these pieces, enlarge the central hole so that the ball will pass. These are the entrance and exit holes.

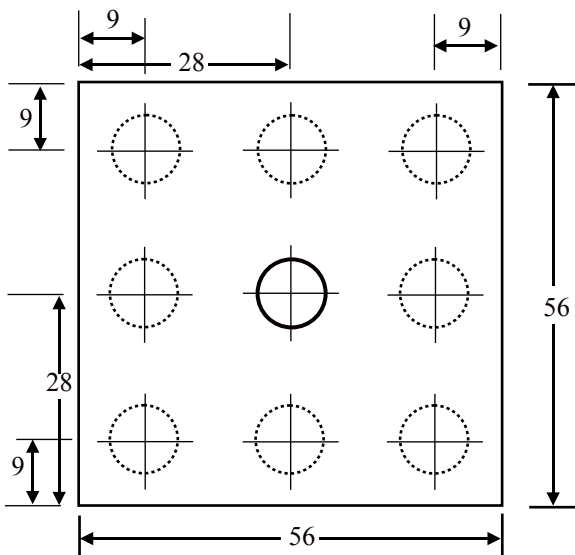

Cut six pieces each 56mm x 18mm, and drill these three 9mm holes in each piece.

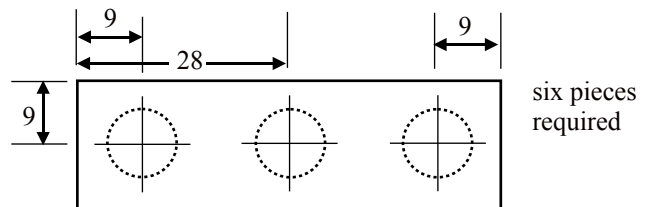

In four of these pieces, cut two slots extending halfway across the piece. These slots are just wide enough to accommodate the thickness of the plastic.

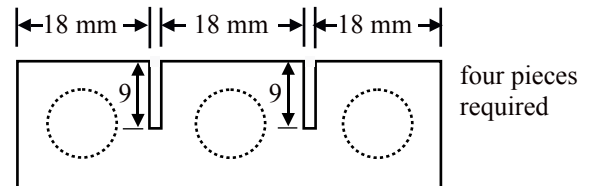

Take the other four 56 x 56 pieces, and cut these slots in them. The shorter slots are to take the narrow pieces, and the longer slots go halfway across: two of these pieces will slot into the other two pieces. The single inner slots should be 18mm wide. These will take the two single strips that have no slots.

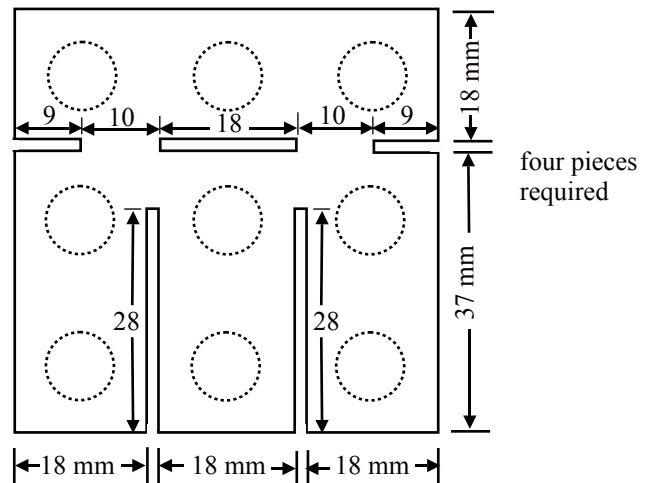

Lay all these pieces down.  
 These will be the inside panels.  
 Lightly mark the pieces, to see  
 how they will slot together.

The four square pieces are the  
 vertical panels, and they will  
 slot together, at points  
 A,B,C and D.

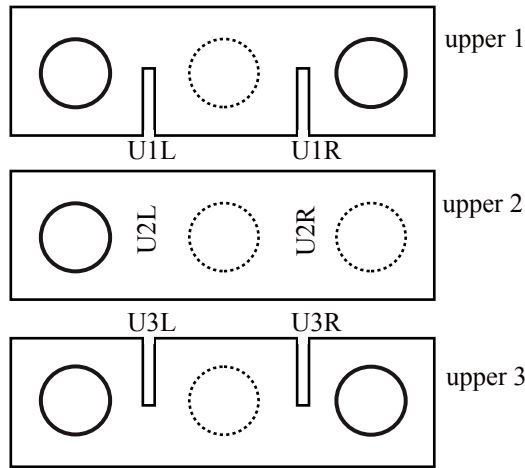
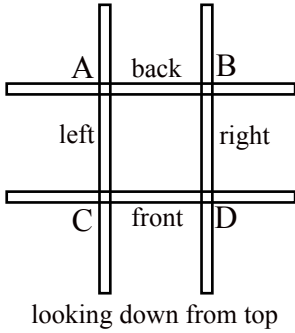

The Upper layer strips:  
 Upper 1 and Upper 3 will  
 slot into the inner left and  
 right panel side slots.  
 Upper 2 should fit through  
 the inner slots in the inner  
 left and right panels..

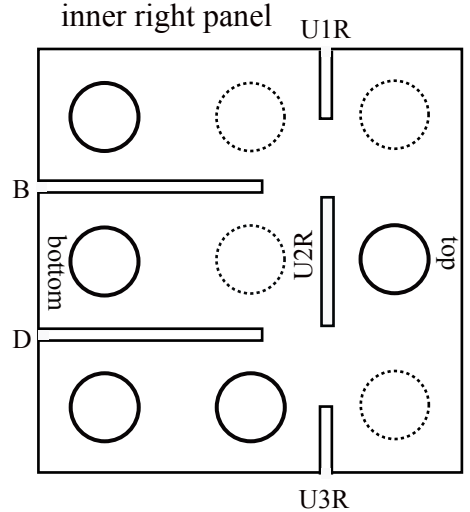
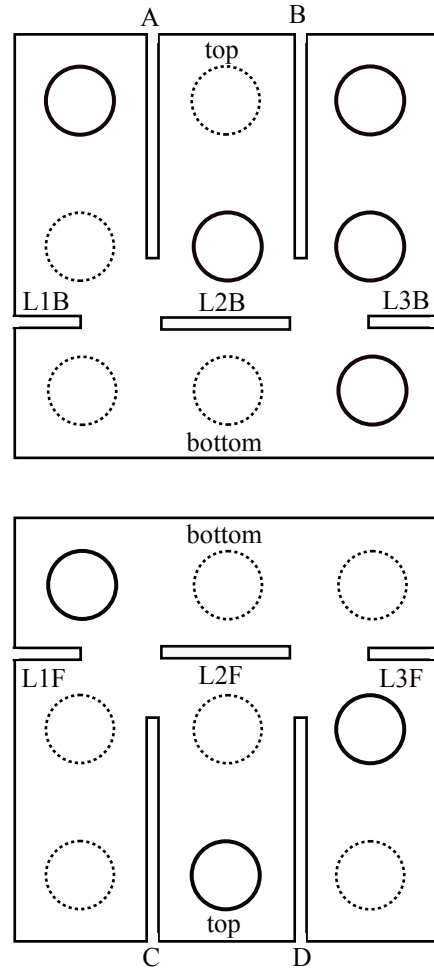
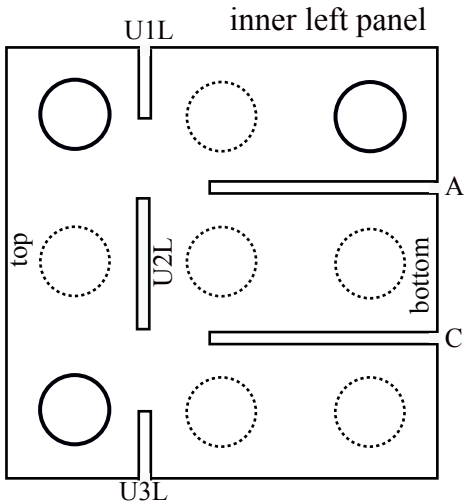

The Lower layer strips:  
 Lower 1 and Lower 3 will  
 slot into the inner back and  
 front panel side slots.  
 Lower 2 should fit through  
 the inner slots in the inner  
 back and front panels..

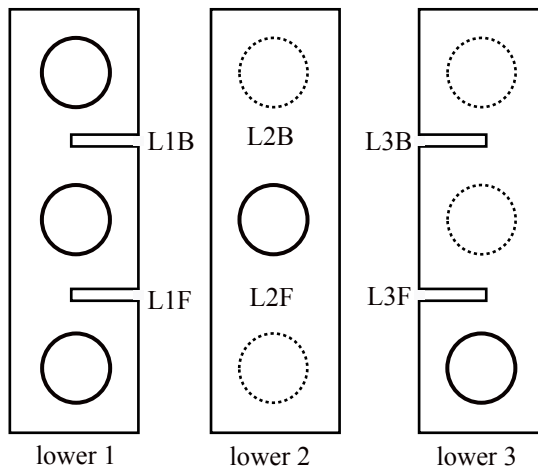

**IMPORTANT!**  
 All the holes with a  
**solid black line** should  
 be enlarged to allow the  
 ball bearing **through**.  
 All the holes with a  
 dotted line should **NOT**  
 allow the ball through.

Using a non-permanent marker, lightly mark the "passable" holes, and slot all the inner pieces together. They should support themselves. Before the outer panels are put on, you can trace the route through the maze by following the temporary marks. Note that there are a couple of "dead ends" in this route, because I didn't want any space to be "not used". If it seems okay, the outer panels can be put on, and temporarily held in place with elastic bands. Make sure that the front outer panel (with the middle entrance hole) is in front of the inner front panel. The entrance should be just above the L2 strip. The back outer panel exit hole should also be just above the L2B strip. These entrance and exit holes could be marked with a permanent marker. Now drop the ball bearing in, and following your temporary marks, see if the ball will actually go right through the maze.

If everything is all right, remove the elastic bands, and take the inner panels apart, remove the temporary marks, and re-assemble the inside. Be careful not to mix up the panels! Refit the outer panels, and apply some plastic model cement to the edges. If you haven't got plastic cement, you could use superglue. Now that the inner panels are surrounded on all sides, they shouldn't need to be cemented in place, but you can if you wish.

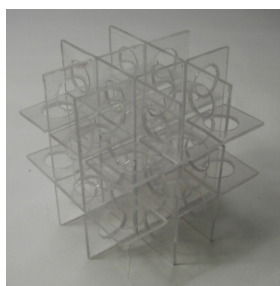
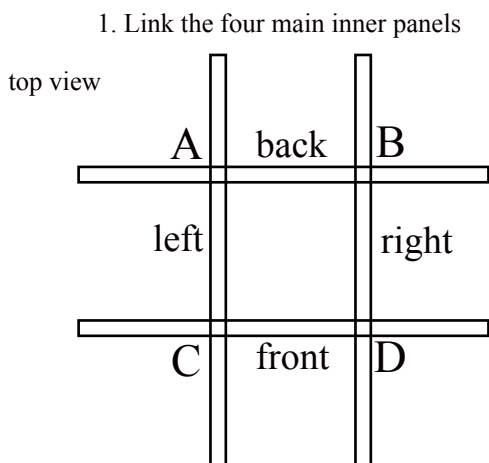

Inner panels assembled

Notice how the 57 x 58 mm outer panels overlap at one end, and overlap both front and back. The front and back panels (the ones with the entrance and exit holes) should fit inside these front and back overlaps.

2. Insert the lower panels

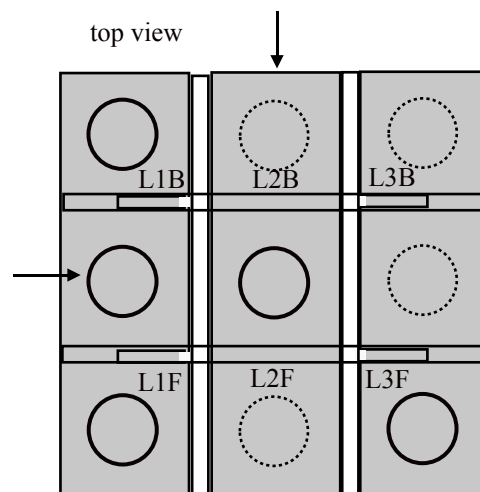

Putting the lower panels in place

3. Insert the upper panels

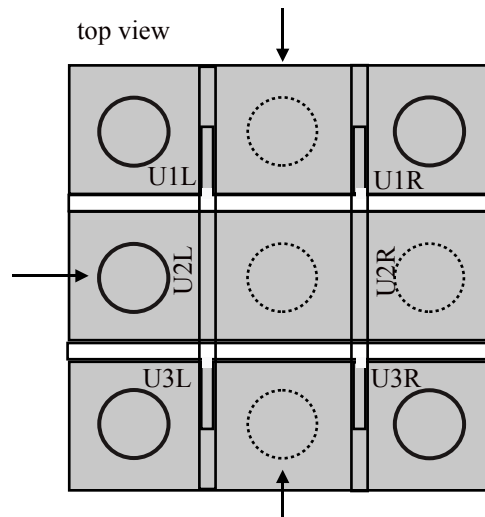

Putting the upper panels in place

4. Glue on the outer panels

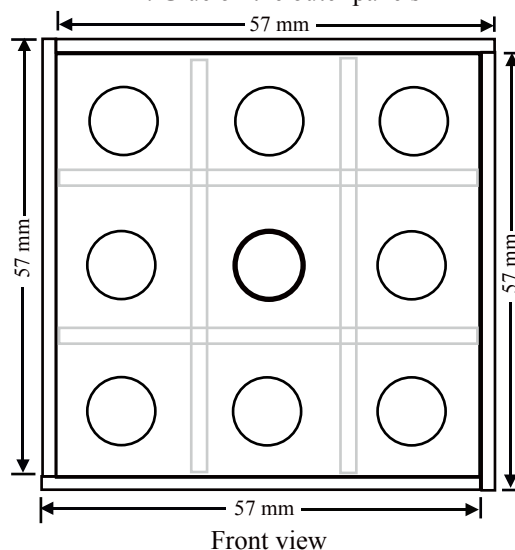

I've taken every care in preparing these plans. However, if you find something wrong, please let me know, so that I can put it right.

Enjoy your puzzle!

These plans are free.  
 If you sell or give away this puzzle,  
 please mention where the plans came from.  
 © Bruce Viney. January, 2007

Get more plans and solutions at **Homemade Puzzles**.  
 Web address: [www.homemadepuzzles.co.uk](http://www.homemadepuzzles.co.uk)  
 E-mail: [bruce@homemadepuzzles.co.uk](mailto:bruce@homemadepuzzles.co.uk)