

Chinese Torture T-Plans (New)

Homemade Puzzles

This puzzle box is a cube with two sliding panels on each side. The outer panels slide in one direction, then both outer panels will slide in another direction. Both panels on each side will have to be moved to release a set of panels from one side. But most of the panels can be moved too far, stopping you from opening the box. Some of these blocking moves are not apparent until you reach almost the end of the moves, only to find you can't make that last move.

Not too difficult to make, Assembly is a little tricky, but these plans take you through step-by-step.

The size of this box is 3" by 3" by 3", if made from 1/8" wood, but these plans are T-Plans, which allow you to make this at any size.



Note: Any Chinese Torture plan dated earlier than March, 2010 is flawed.

T represents the thickness of your wood.

Start with the top panel:

Cut these pieces:

- cut one at 20T by 20T: top panel.
- cut one at 16T by 16T: outer 1 panel.
- cut one at 14T by 14T: outer panel 2.
- cut one at 12T by 3T: slider guide 1.
- cut one at 12T by 4T: slider.
- cut one at 12T by 3T: slider guide 2.
- cut one at 9T by 4T: panel slider.
- cut two at 16T by 16T: inner 1 and 2 panels.

cut out this slot in the outer 1 panel:

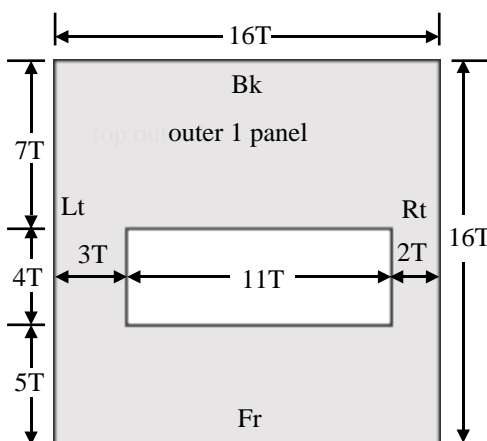

cut out this hole in the top panel:

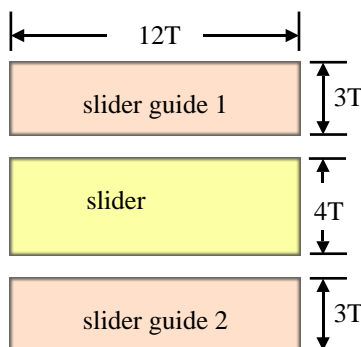
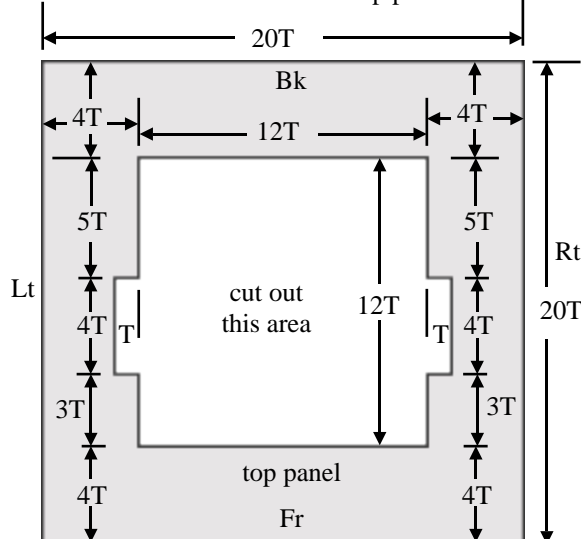

Glue the inner 1 and 2 panels together.

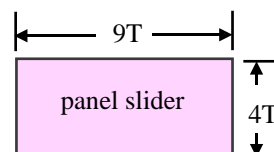

A 6 inch (150mm) length of dowel rod, of diameter 1/8" (3mm) will be required. Cut into six equal lengths, and put to one side.

Notice the letters in the edges of the panels. You should put these on for reference later.

Bk=back
Fr=front
Lt=left
Rt=right

What is a T-Plan?
See page 19

Assembly of the top panel.

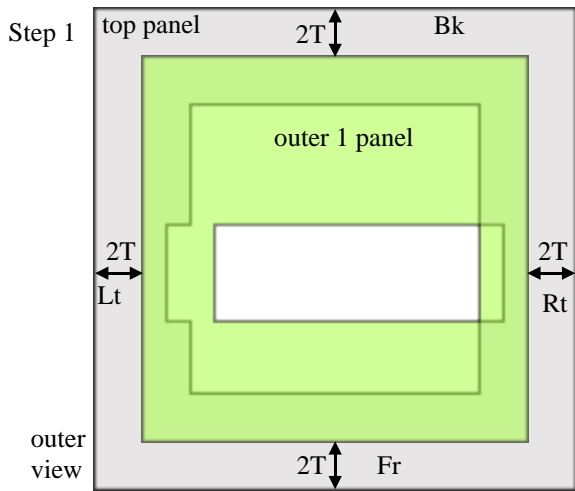

Lay the top panel down, and position the outer 1 panel centrally onto it, as shown.

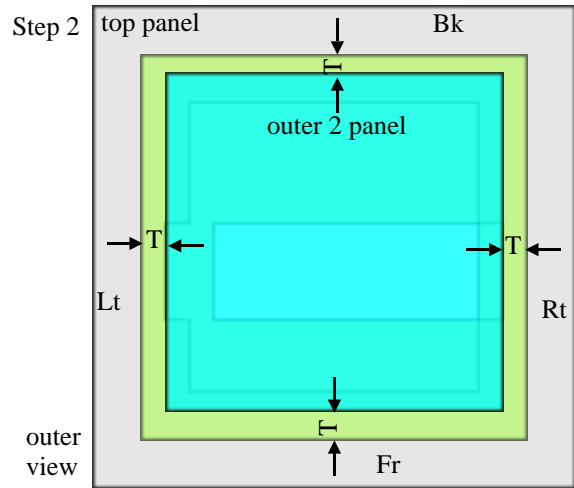

Position the outer 2 panel centrally onto the outer 1 panel. Using clear tape, secure the three pieces together.

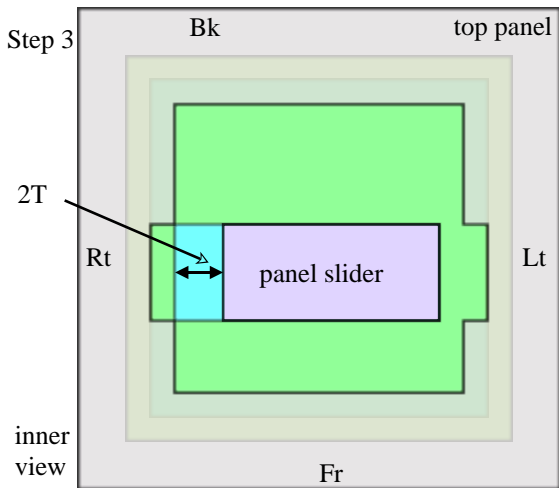

Turn the assembly over, left to right. Place the panel slider in the slot in the outer 1 panel, in the position shown. It will be resting on the inside face of the outer 2 panel. Make sure the panel slider can move towards the right end a distance of 2T.

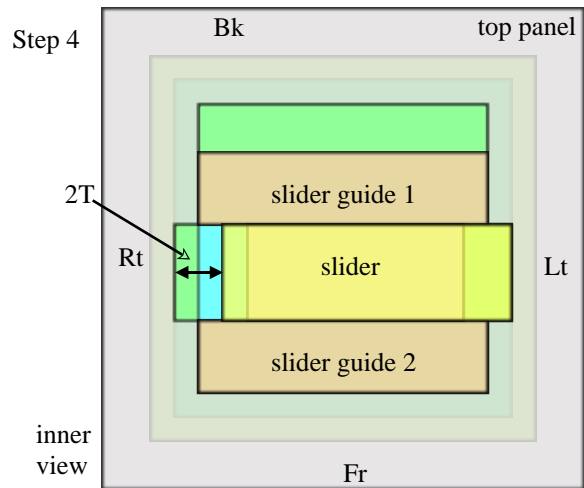

Place the slider guide 2, the slider and the slider guide 1 into the hole in the top panel, in the positions shown. Make sure the slider can move towards the right end a distance of 2T.

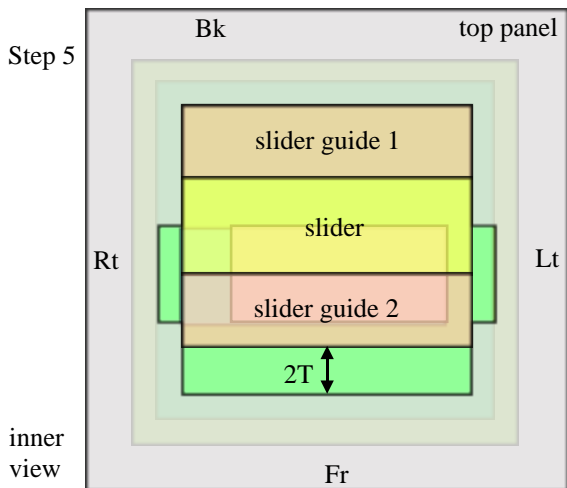

With the slider halfway, make sure that the two guides and slider can move towards the back edge a distance of 2T.

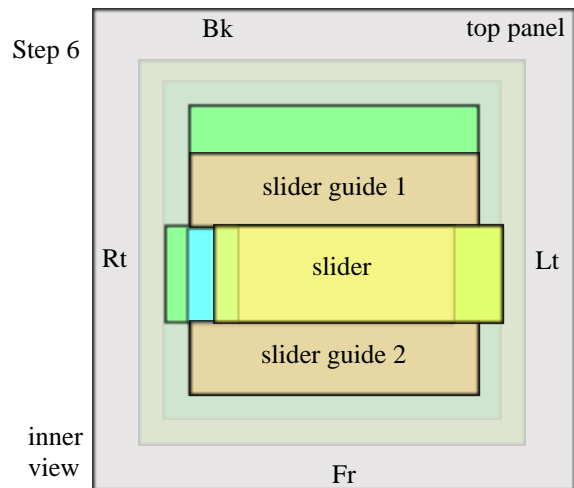

When the parts are moving properly, glue the two guides into their original positions. Take care not to glue either of the sliders.

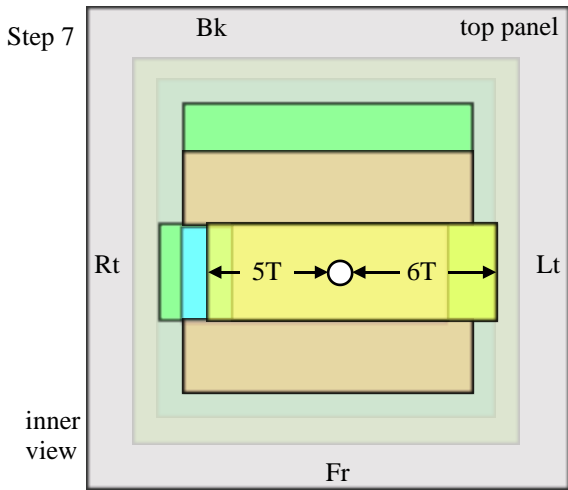

With the sliders and guides in their original positions, drill a hole, of diameter 1/8" (3mm) in the position shown, right through all the layers.

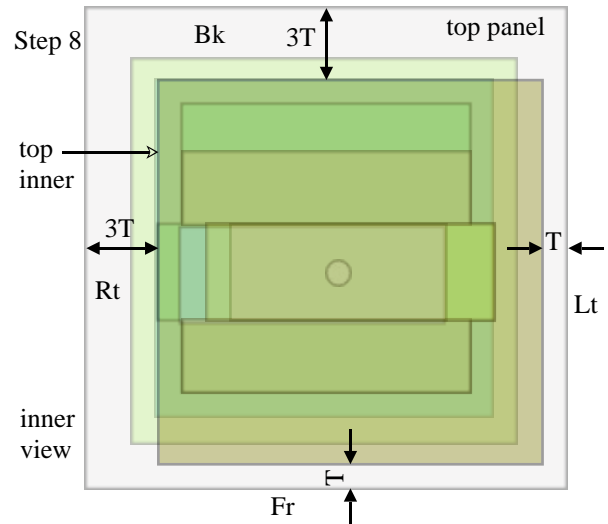

Place the top inner panel (now made up of two layers), onto the top panel in the position shown. Using clear tape, secure it in place.

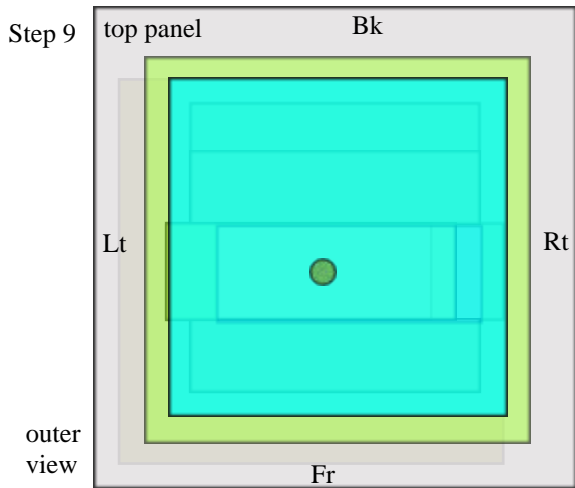

Turn the whole assembly over, left to right, so the outer panels are upwards again. Using the same drill size, continue the hole right through all the panels.

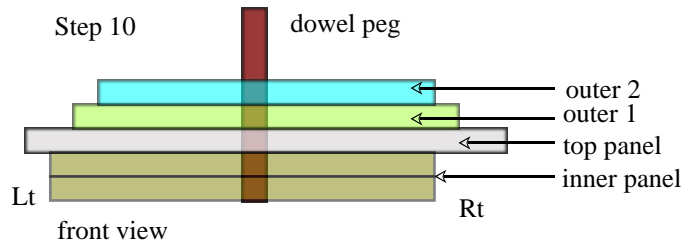

Insert one of the dowel pegs right through all the layers, and remove the clear tape. The peg will hold the whole panel together, and still allow the moving parts to move. Note that the dowel hole in the outer 2 panel will not be in the centre. The end of the peg will be covered later.

Put this top panel to one side.

The left panel.

Cut these pieces:

- cut one at 19T by 18T: left panel.
- cut one at 16T by 16T: outer 1 panel.
- cut one at 14T by 14T: outer panel 2.
- cut one at 11T by 3T: slider guide 1.
- cut one at 11T by 4T: slider.
- cut one at 11T by 3T: slider guide 2.
- cut one at 8T by 4T: panel slider.
- cut one at 16T by 16T: inner 1 panel.
- There is no inner 2 panel.

Cut out this slot in the outer 1 panel:

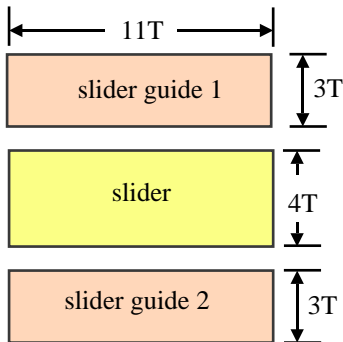
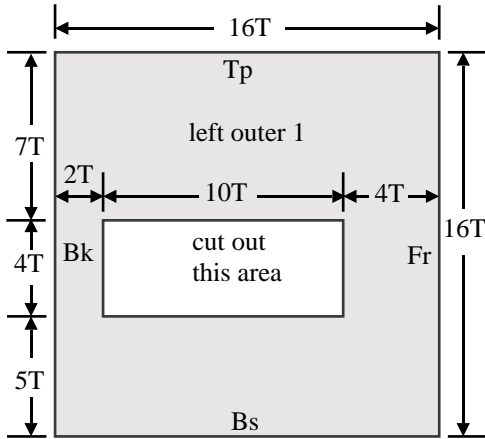

Cut out this hole in the left panel:

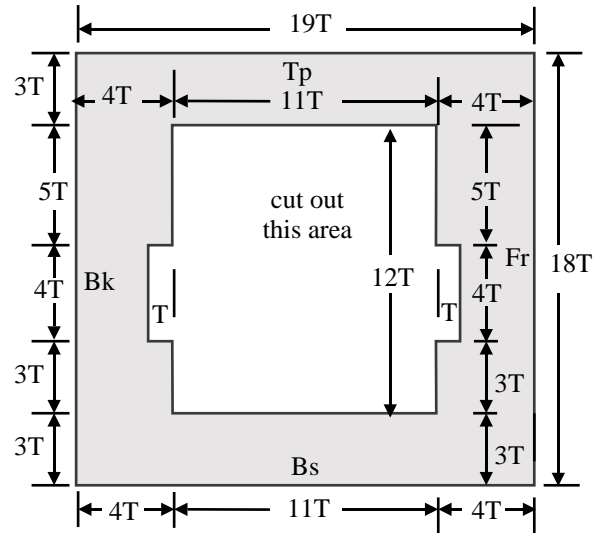

cut the left inner panel to this shape:

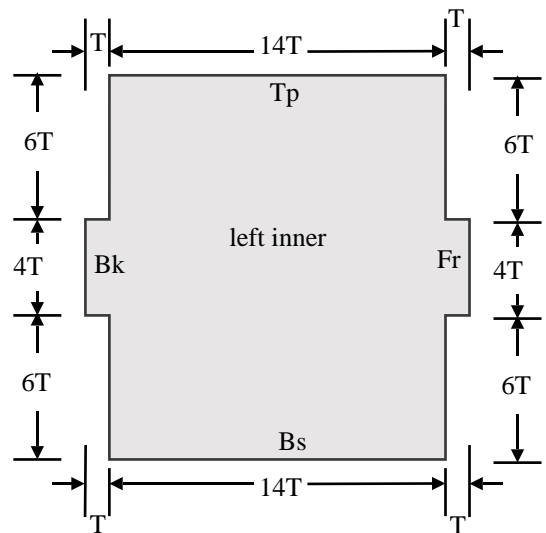

Assembly of the left panel

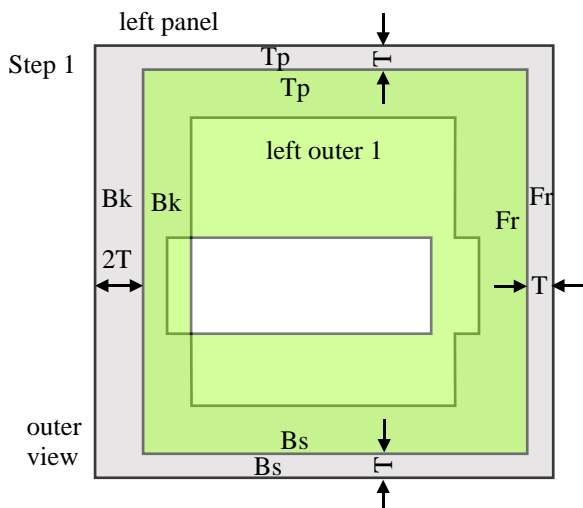

Lay the left panel down, and place the outer 1 panel onto it, in the position shown.

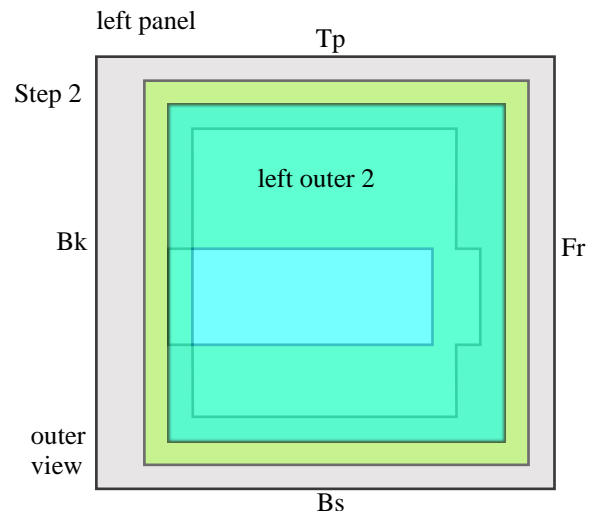

Position the outer 2 panel centrally onto the outer 1 panel. Using clear tape, secure the three pieces together.

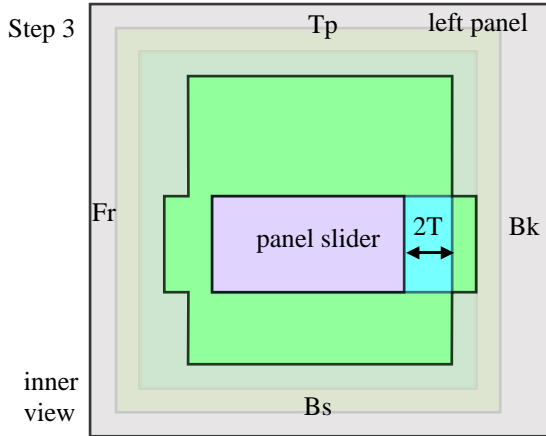

Turn the assembly over, front to back. Place the panel slider in the slot in the outer 1 panel, in the position shown. It will be resting on the inside face of the outer 2 panel. Make sure the panel slider can move towards the back end a distance of 2T.

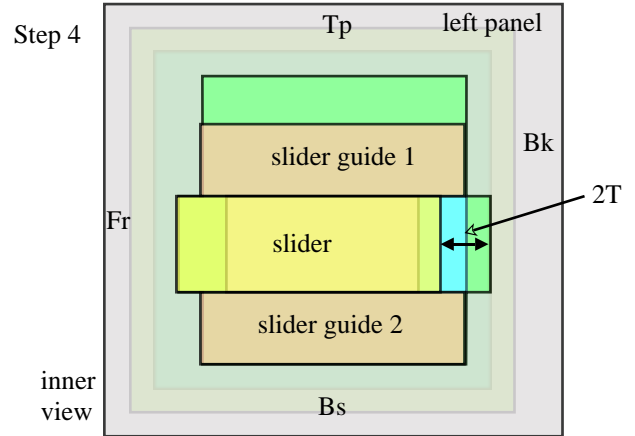

Place the slider guide 2, the slider and the slider guide 1 into the hole in the top panel, in the positions shown. Make sure the slider can move towards the back end a distance of 2T.

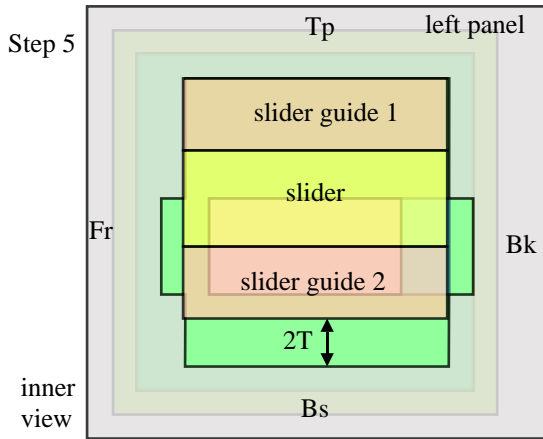

With the slider halfway, make sure that the two guides and slider can move towards the top edge a distance of 2T.

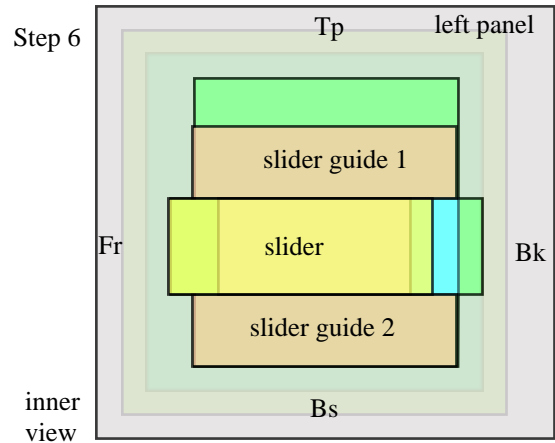

When the parts are moving properly, glue the two guides into their original positions. Take care not to glue either of the sliders.

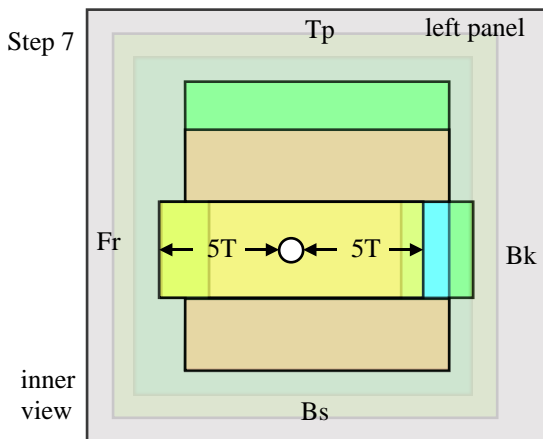

With the sliders and guides in their original positions, drill a hole, of diameter 1/8" (3mm) in the position shown, right through all the layers.

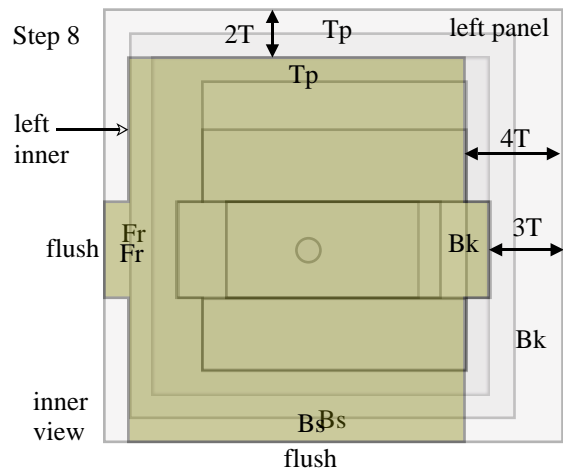

Place the left inner panel onto the left panel in the position shown. Using clear tape, secure it in place.

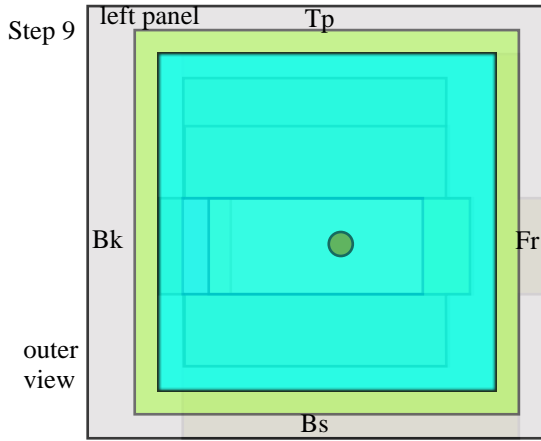

Turn the whole assembly over, front to back, so the outer panels are upwards again. Using the same drill size, continue the hole right through all the panels.

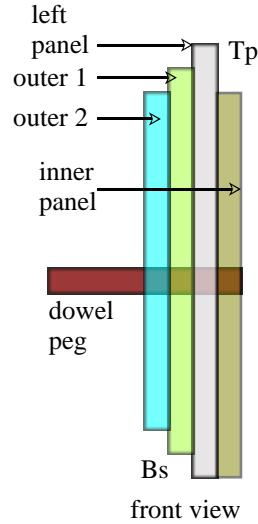

Step 10

Insert one of the dowel pegs right through all the layers, and remove the clear tape. The peg will hold the whole panel together, and still allow the moving parts to move. Note that the dowel hole in the outer 2 panel will not be in the centre. The end of the peg will be covered later.

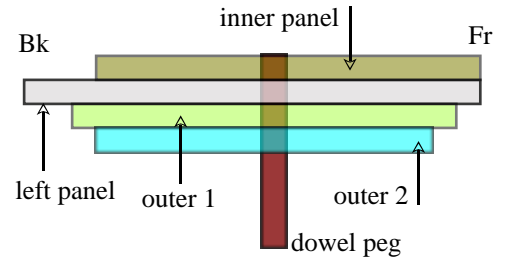

Put this left panel to one side.

top view

The Front Panel.

Cut these pieces:

- cut one at 19T by 18T: front panel.
- cut one at 16T by 16T: outer 1 panel.
- cut one at 14T by 14T: outer panel 2.
- cut one at 12T by 3T: slider guide 1.
- cut one at 12T by 4T: slider.
- cut one at 12T by 4T: slider guide 2.
- cut one at 8T by 4T: panel slider.
- cut one at 16T by 16T: inner 1 panel.
- cut one at 16T by 15T: inner 2 panel.

Cut out this hole in the front panel:

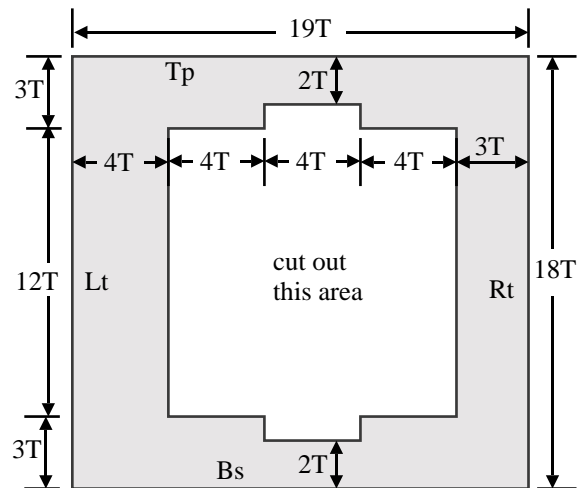

Cut out this slot in the outer 1 panel:

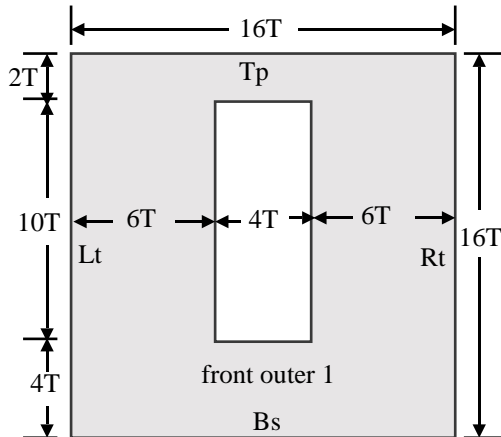

cut the front inner 2 panel to this shape

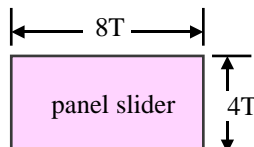
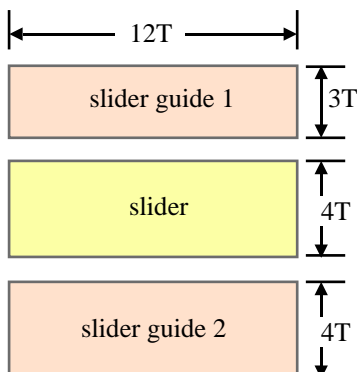
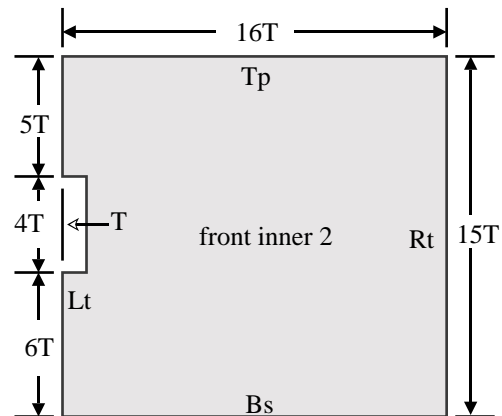

Assembly of front panel.

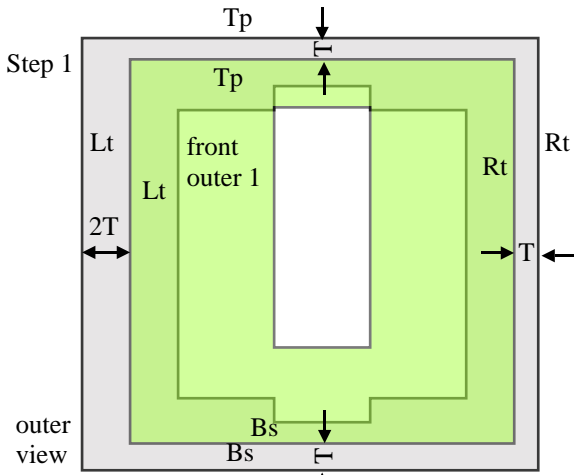

Lay the front panel down, and place the outer 1 panel onto it, in the position shown.

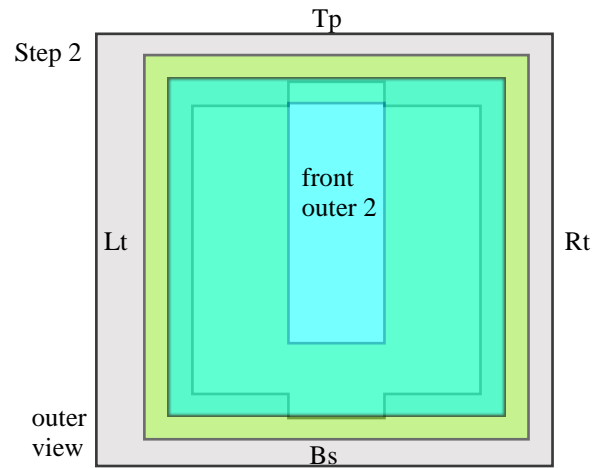

Position the outer 2 panel centrally onto the outer 1 panel. Using clear tape, secure the three pieces together.

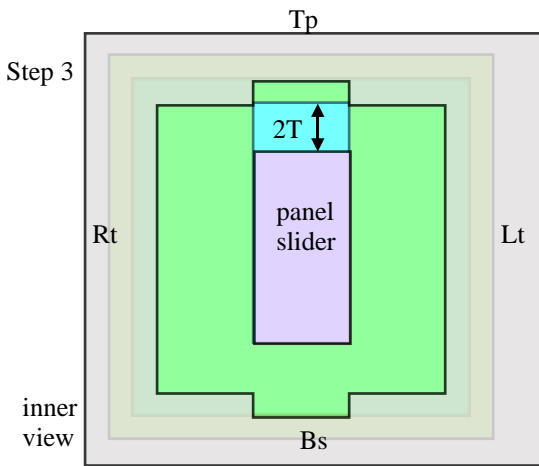

Turn the assembly over, left to right. Place the panel slider in the slot in the outer 1 panel, in the position shown. It will be resting on the inside face of the outer 2 panel. Make sure the panel slider can move upwards to the top end a distance of 2T.

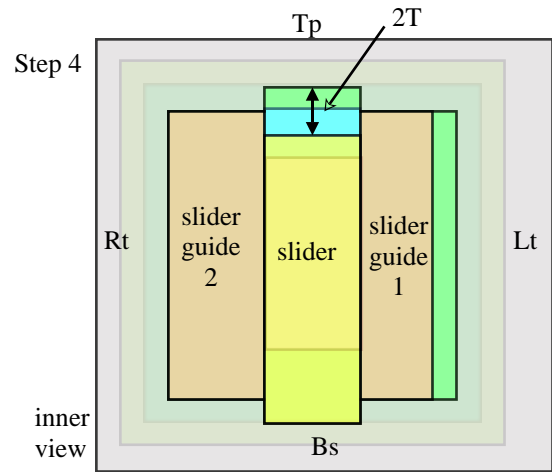

Place the slider guide 2, the slider and the slider guide 1 into the hole in the front panel, in the positions shown. Make sure the slider can move upwards to the top end a distance of 2T.

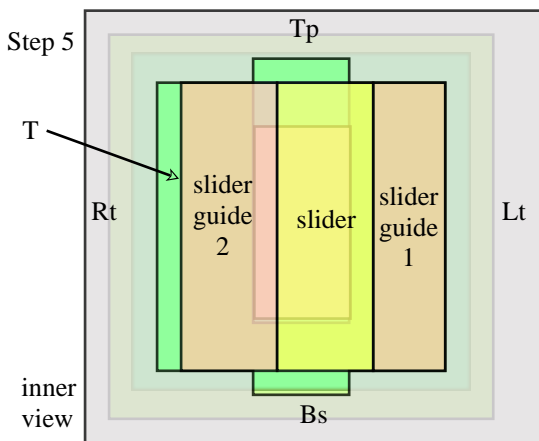

With the slider halfway, make sure that the two guides and slider can move towards the right end a distance of T.

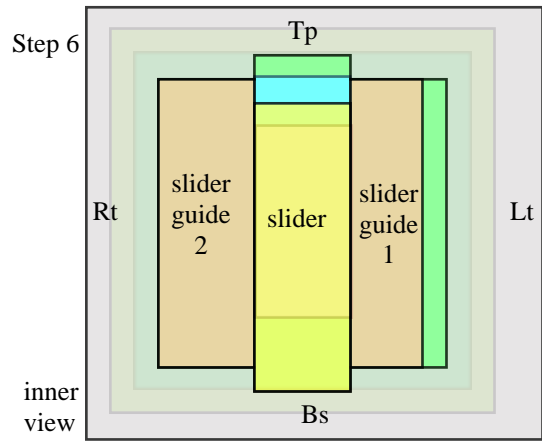

When the parts are moving properly, glue the two guides into their original positions. Take care not to glue either of the sliders.

Assembly of front panel.

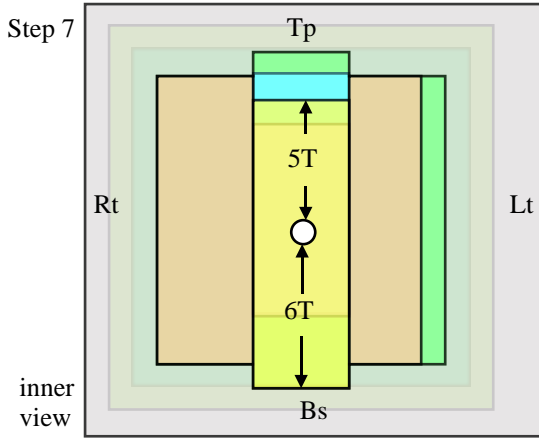

With the sliders and guides in their original positions, drill a hole, of diameter 1/8" (3mm) in the position shown, right through all the layers.

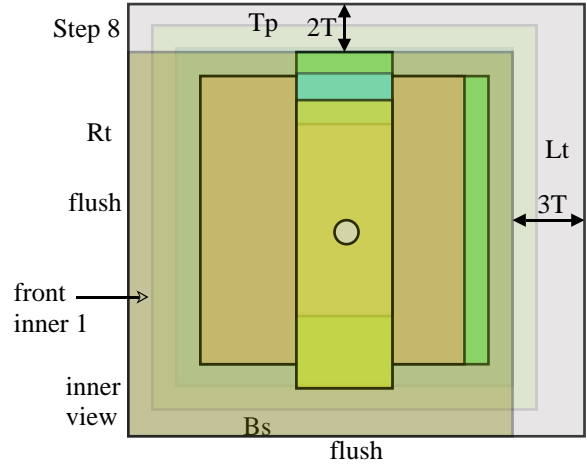

Place the front inner 1 panel onto the front panel in the position shown.

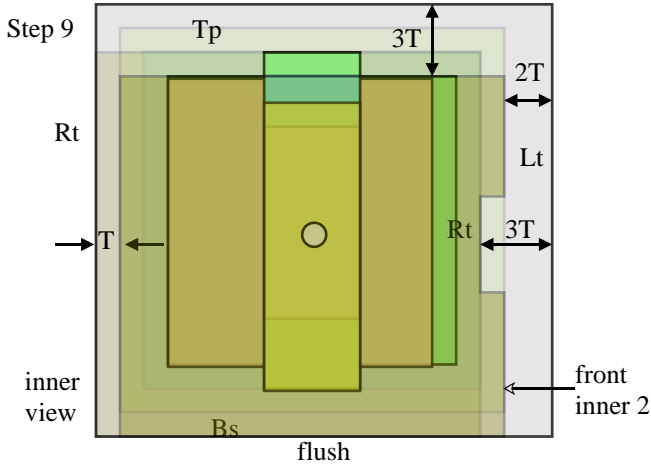

Place the front inner 2 panel onto the front inner 1 panel in the position shown. Using clear tape, secure these two inner panels to the front panel.

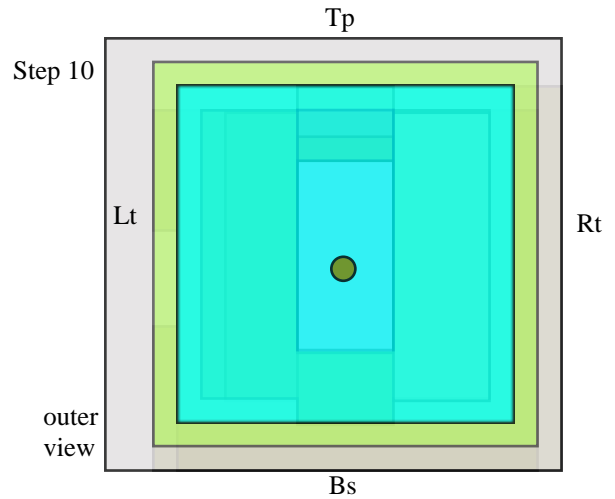

Turn the whole assembly over, left to right, so the outer panels are upwards again. Using the same drill size, continue the hole right through all the panels.

Step 11 Insert one of the dowel pegs right through all the layers, and remove the clear tape. The peg will hold the whole panel together, and still allow the moving parts to move. Note that the dowel hole in the outer 2 panel will not be in the centre. The end of the peg will be covered later.

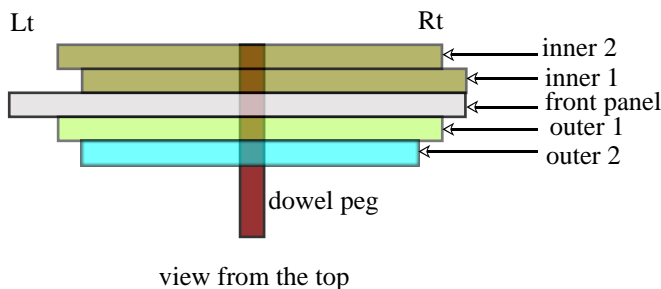
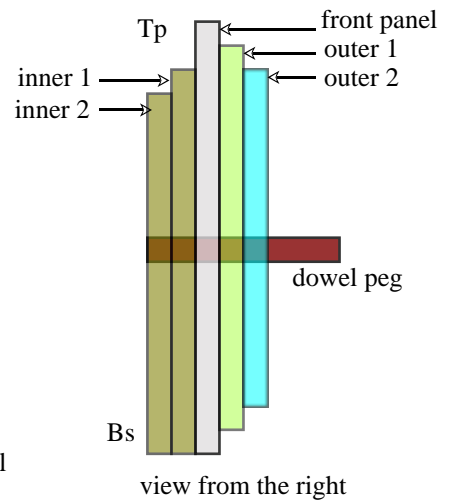

Assembly of first three panels.

At this point, it's best to glue the first three sides together, to see if they will work properly, and to make the assembly of the last three panels that bit easier.

The top panel controls the vertical movement of the left, front, right and back panels.

The left panel controls the horizontal movement of the front panel, and the vertical movement of the back panel.

The front panel controls the horizontal movement of the right panel (which is not yet made).

So it's important to get these first three sides working correctly, before going any further.

Glue only down the front edge of the left panel.

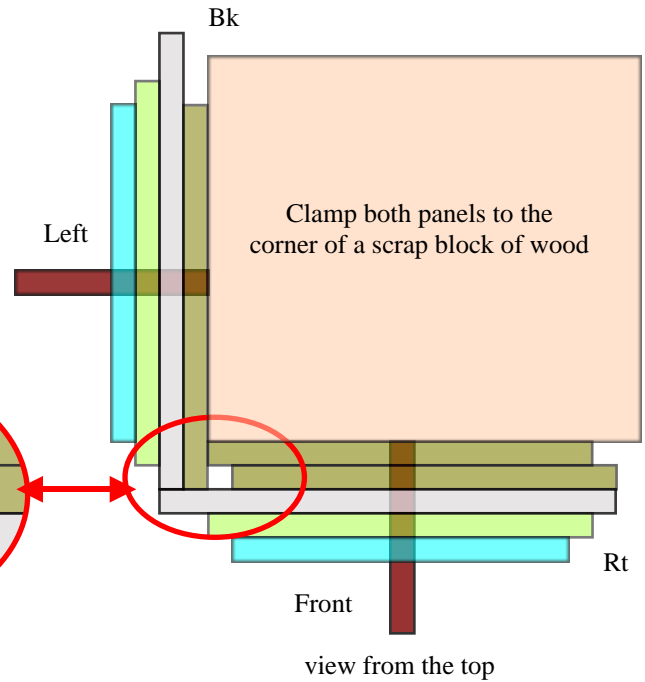
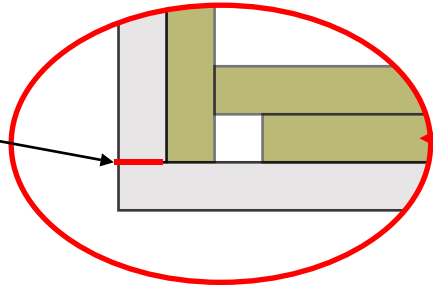

Glue the front panel to the front edge of the left panel. The left panel's moving parts can be pushed toward the back, to avoid getting any glue on them. To keep the panels square, clamp both of them to the corner of a block of wood.

Position the top panel on top of the two panels, making sure it's the right way round, and glue to the top edges of the left and front panels.

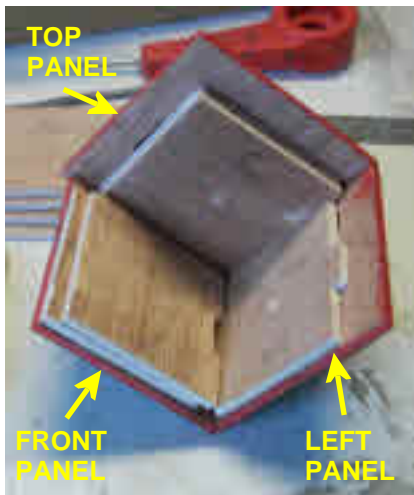

Left, front and top panels glued together. The inner ends of the dowel pegs are visible in this photo. Notice that the top panel overlaps the right edge of the front panel. The right panel will overlap the right edge of the front panel, and the right panel's top edge will be overlapped by the top panel.

Cut these pieces:

- cut one at 19T by 18T: right panel.
- cut one at 16T by 16T: outer 1 panel.
- cut one at 14T by 14T: outer panel 2.
- cut one at 12T by 3T: slider guide 1.
- cut one at 12T by 4T: slider.
- cut one at 12T by 4T: slider guide 2.
- cut one at 8T by 4T: panel slider.
- cut one at 17T by 16T: inner panel.
- There is no inner 2 panel.

Cut out this slot in the outer 1 panel:

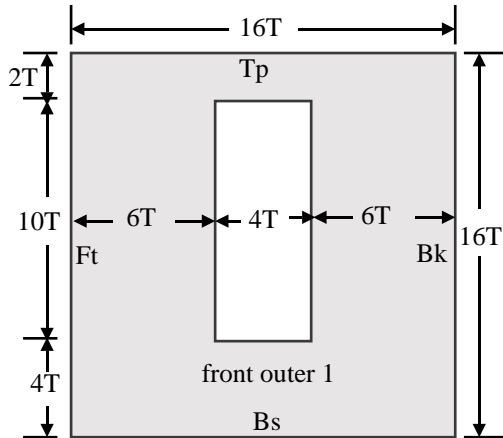

Cut out this hole in the right panel:

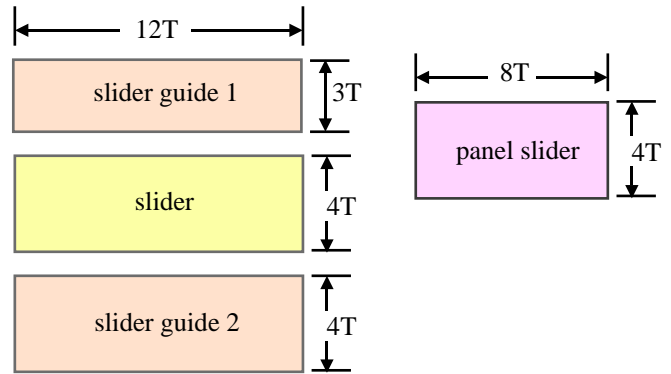
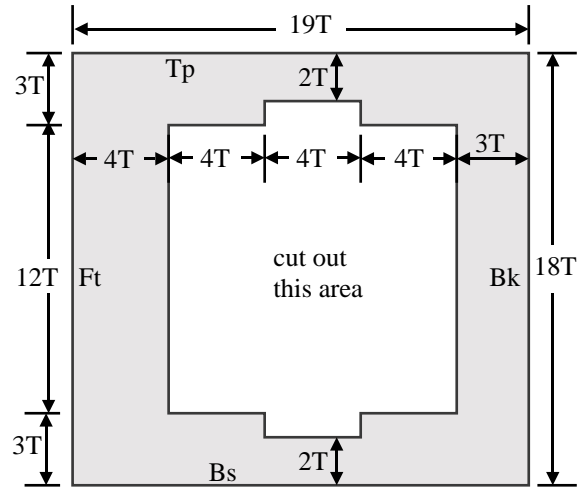

Assembly of the right panel

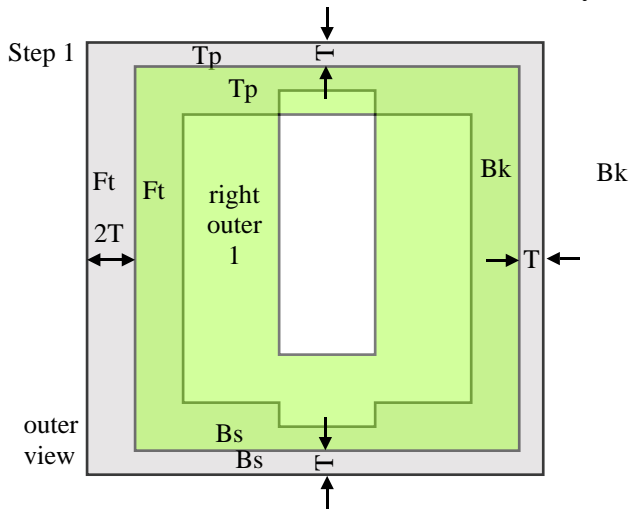

Lay the right panel down, and place the outer 1 panel onto it, in the position shown.

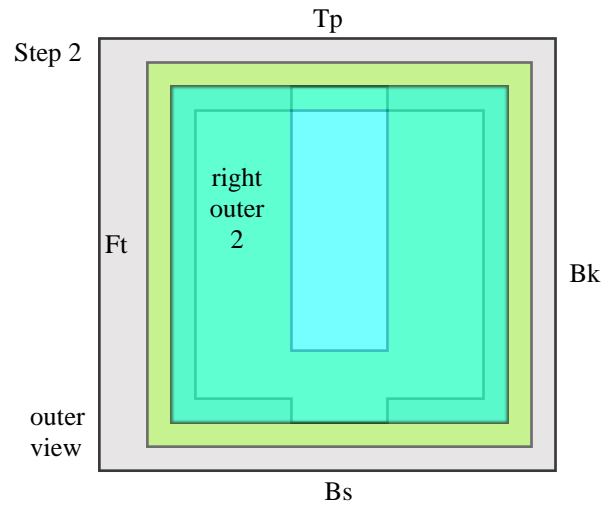

Position the outer 2 panel centrally onto the outer 1 panel. Using clear tape, secure the three pieces together.

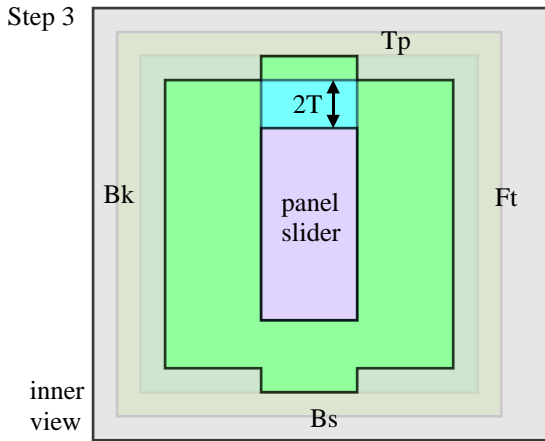

Turn the assembly over, back to front. Place the panel slider in the slot in the outer 1 panel, in the position shown. It will be resting on the inside face of the outer 2 panel. Make sure the panel slider can move upwards to the top end a distance of 2T.

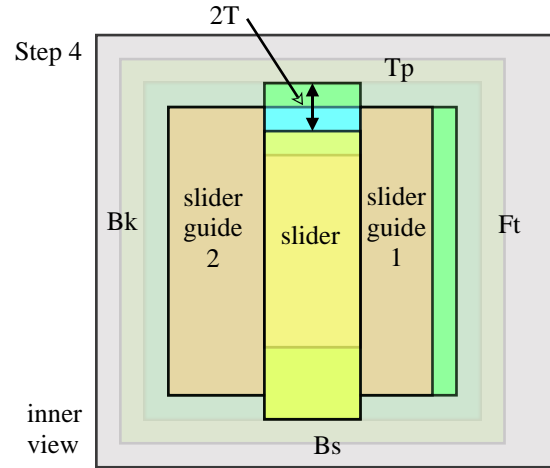

Place the slider guide 2, the slider and the slider guide 1 into the hole in the front panel, in the positions shown. Make sure the slider can move upwards to the top end a distance of 2T.

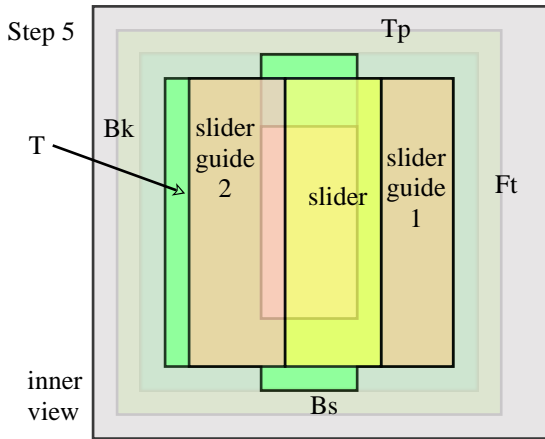

With the slider halfway, make sure that the two guides and slider can move towards the front end a distance of T.

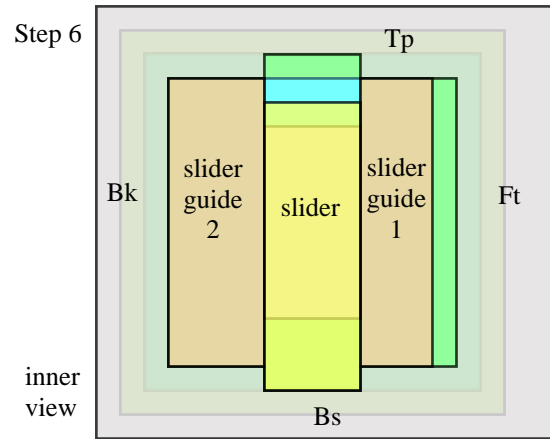

When the parts are moving properly, glue the two guides into their original positions. Take care not to glue either of the sliders.

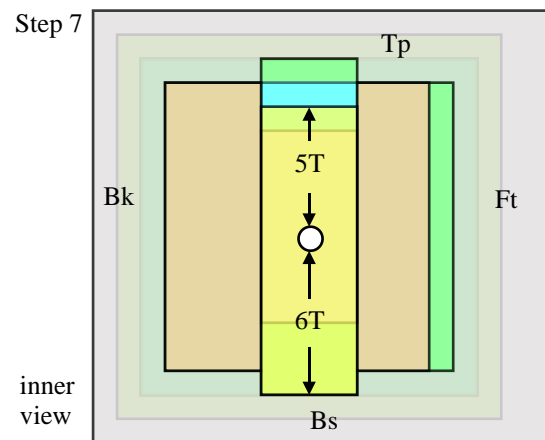

With the sliders and guides in their original positions, drill a hole, of diameter 1/8" (3mm) in the position shown, right through all the layers.

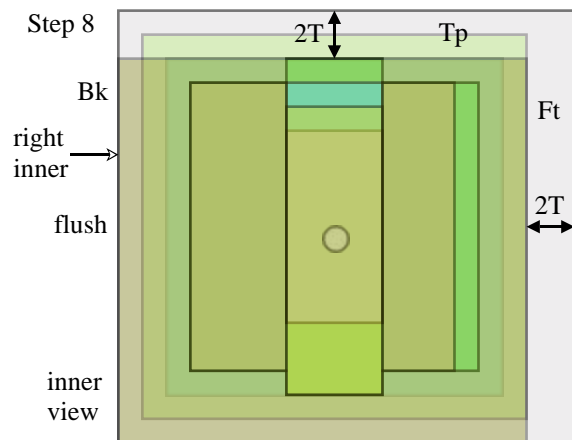

Place the right inner panel onto the right panel in the position shown. Using clear tape, secure it in place.

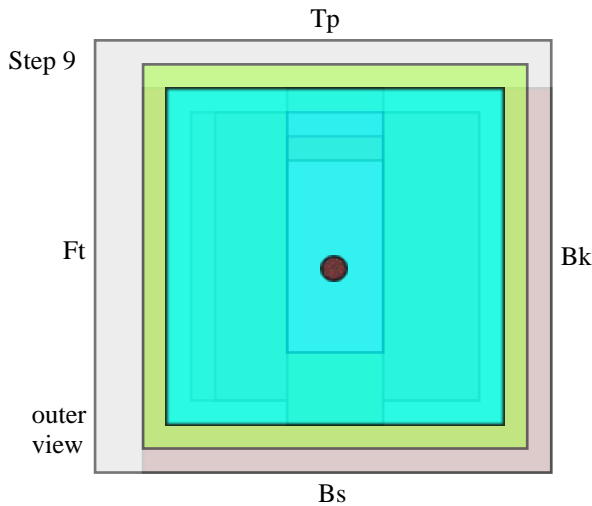

Turn the whole assembly over, back to front, so the outer panels are upwards again. Using the same drill size, continue the hole right through all the panels.

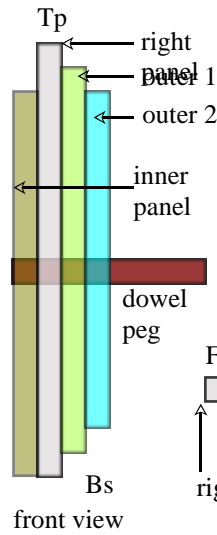

Step 10
Insert one of the dowel pegs right through all the layers, and remove the clear tape. The peg will hold the whole panel together, and still allow the moving parts to move. Note that the dowel hole in the outer 2 panel will not be in the centre. The end of the peg will be covered later.

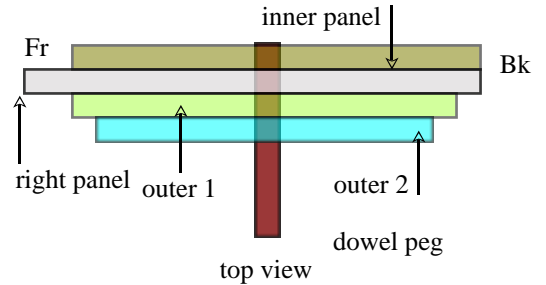

Cut these pieces:

- cut one at 19T by 18T: back panel.
- cut one at 16T by 16T: outer 1 panel.
- cut one at 14T by 14T: outer panel 2.
- cut one at 12T by 3T: slider guide 1.
- cut one at 12T by 4T: slider.
- cut one at 12T by 4T: slider guide 2.
- cut one at 10T by 4T: panel slider.
- cut one at 17T by 16T: inner 1 panel.
- cut one at 15T by 15T: inner 2 panel.

The Back Panel

Cut out this hole in the back panel:

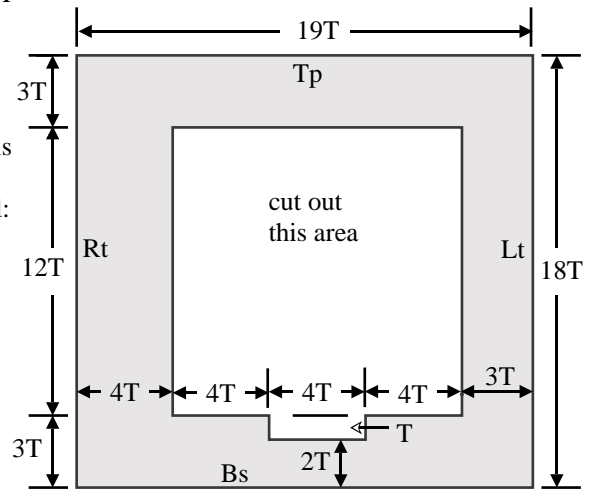

Cut out this slot in the outer 1 panel:

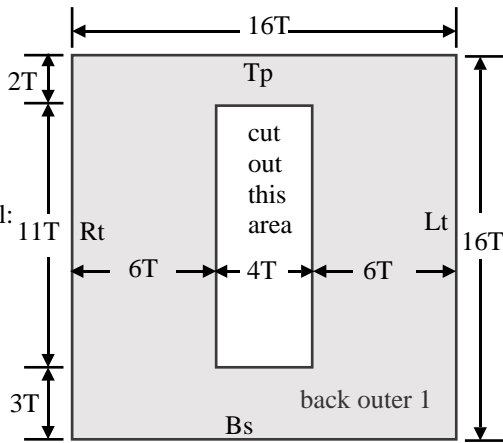

cut the inner 1 panel to this shape:

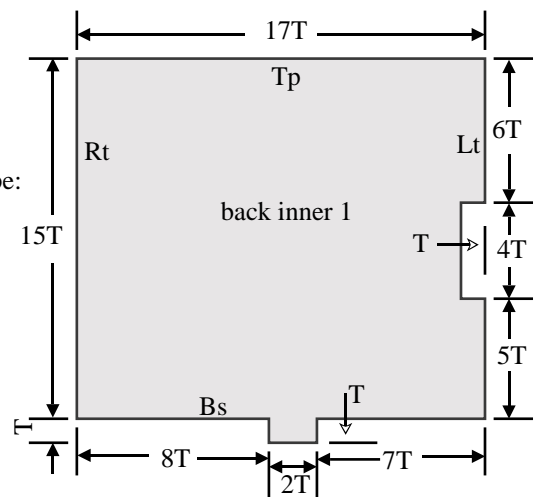

cut the inner 2 panel to this shape:

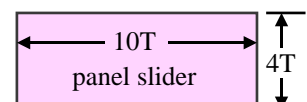
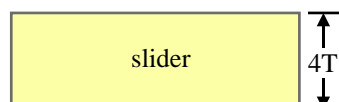
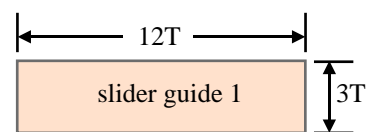
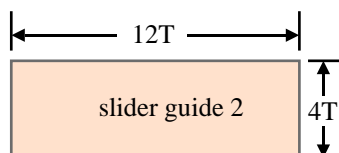
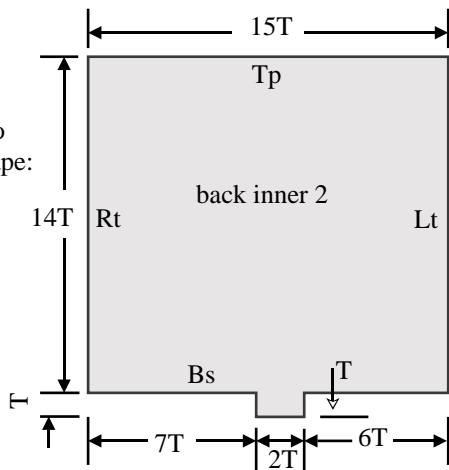

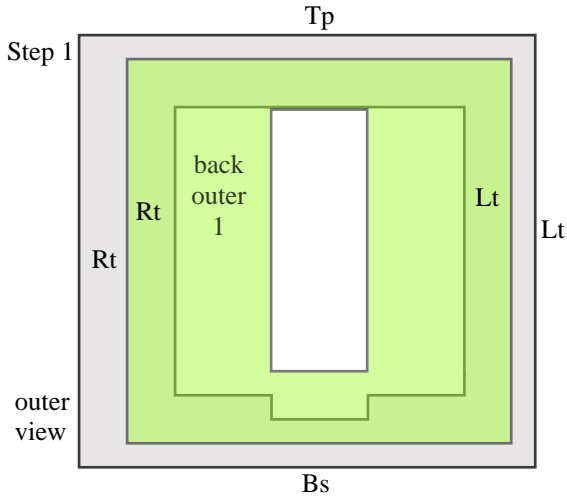

Lay the back panel down, and position the outer 1 panel centrally onto it, as shown.

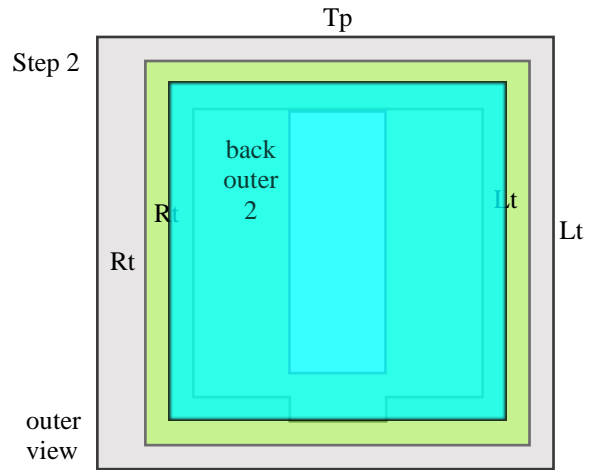

Position the outer 2 panel centrally onto the outer 1 panel. Using clear tape, secure the three pieces together.

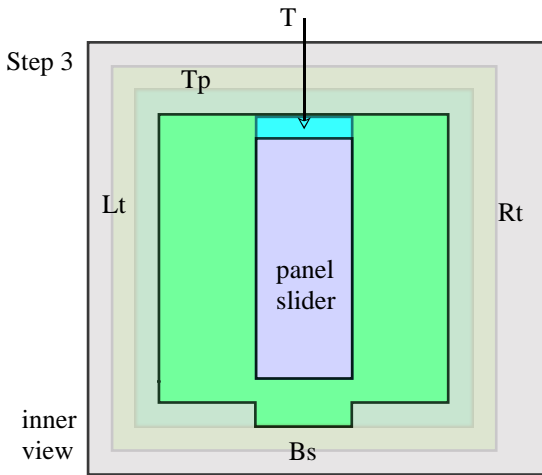

Turn the assembly over, left to right. Place the panel slider in the slot in the outer 1 panel, in the position shown. It will be resting on the inside face of the outer 2 panel. Make sure the panel slider can move upwards towards the top end a distance of T.

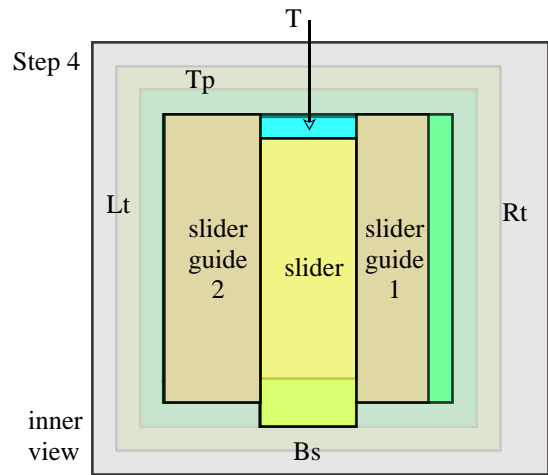

Place the slider guide 2, the slider and the slider guide 1 into the hole in the back panel, in the positions shown. Make sure the slider can move upwards towards the top end a distance of T.

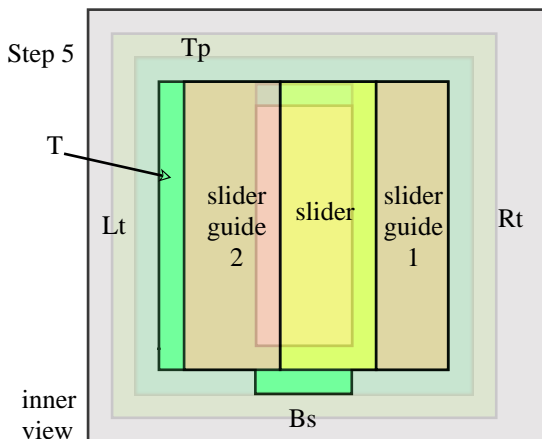

With the slider halfway, make sure that the two guides and slider can move towards the right edge a distance of T.

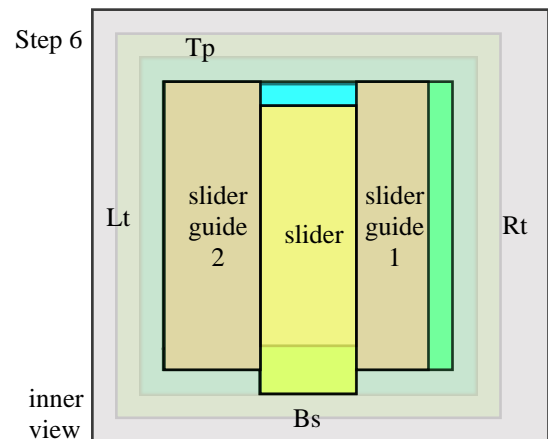

When the parts are moving properly, glue the two guides into their original positions. Take care not to glue either of the sliders.

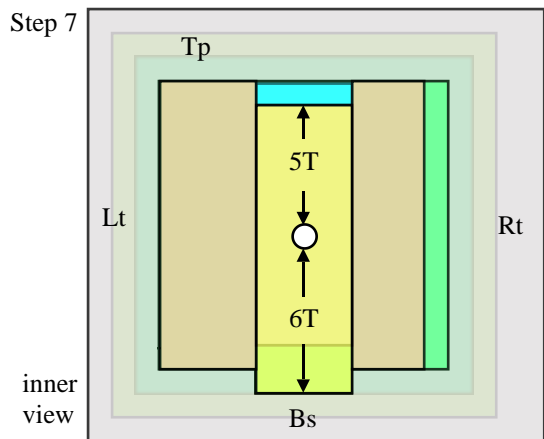

With the sliders and guides in their original positions, drill a hole, of diameter 1/8" (3mm) in the position shown, right through all the layers.

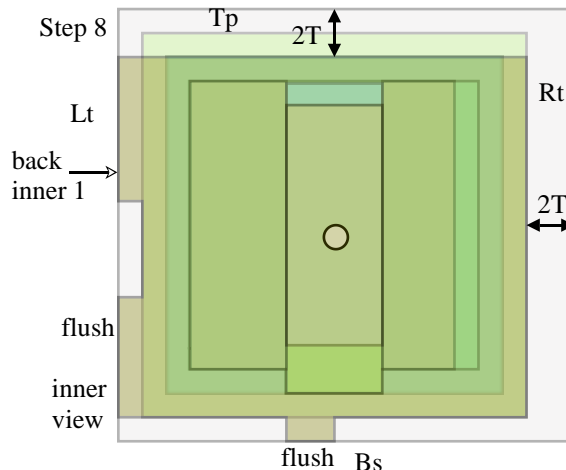

Place the back inner 1 panel onto the back panel in the position shown.

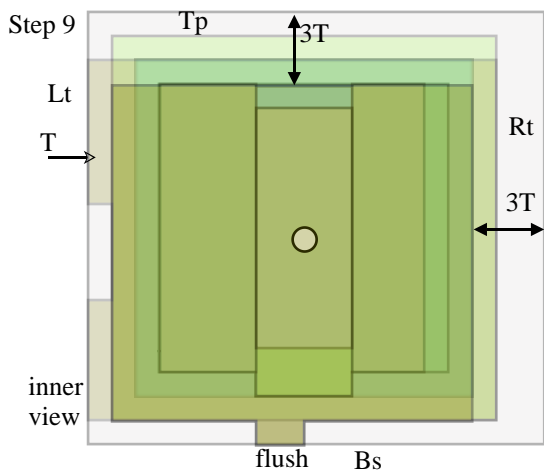

Place the back inner 2 panel onto the back inner 1 panel in the position shown. Using clear tape, secure these two inner panels to the back panel.

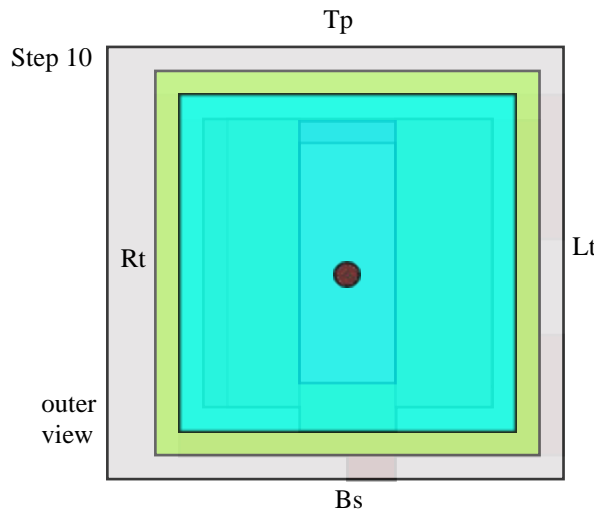

Turn the whole assembly over, left to right, so the outer panels are upwards again. Using the same drill size, continue the hole right through all the panels.

Step 11 Insert one of the dowel pegs right through all the layers, and remove the clear tape. The peg will hold the whole panel together, and still allow the moving parts to move. Note that the dowel hole in the outer 2 panel will not be in the centre. The end of the peg will be covered later.

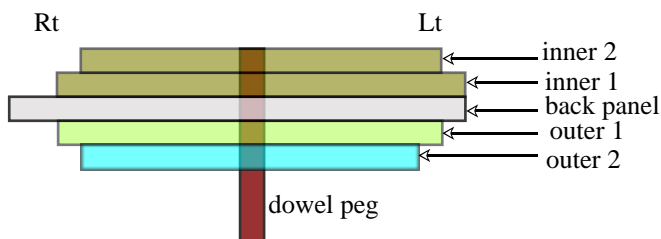

view from the top

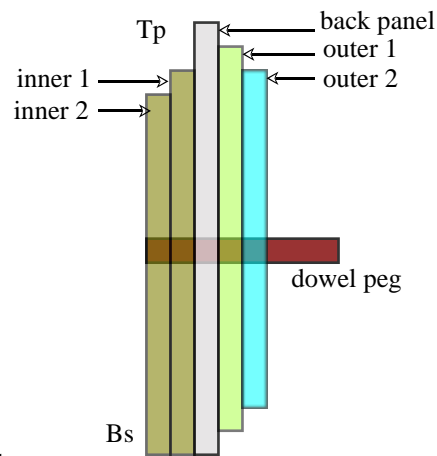

view from the right

Cut these pieces:

- cut one at 20T by 20T: base panel.
- cut one at 16T by 16T: outer 1 panel.
- cut one at 14T by 14T: outer panel 2.
- cut one at 12T by 4T: slider guide 1.
- cut one at 12T by 4T: slider.
- cut one at 12T by 3T: slider guide 2.
- cut one at 8T by 4T: panel slider.
- cut two at 14T by 13T: inner 1 and 2 panels.

Cut out this slot in the base outer 1 panel:

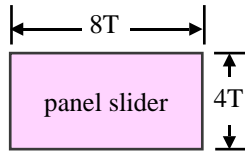
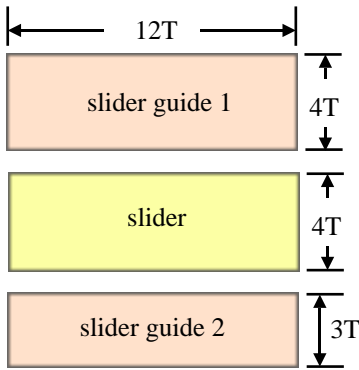
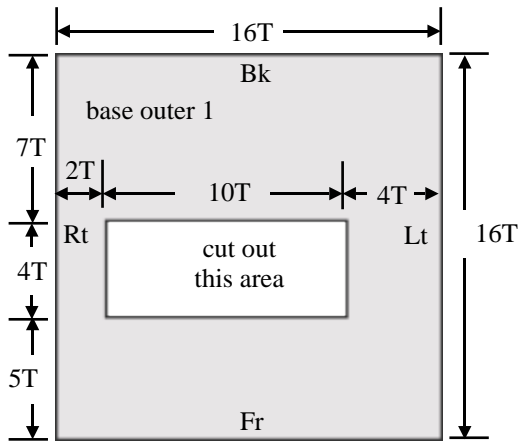

Cut out this hole in the base panel:

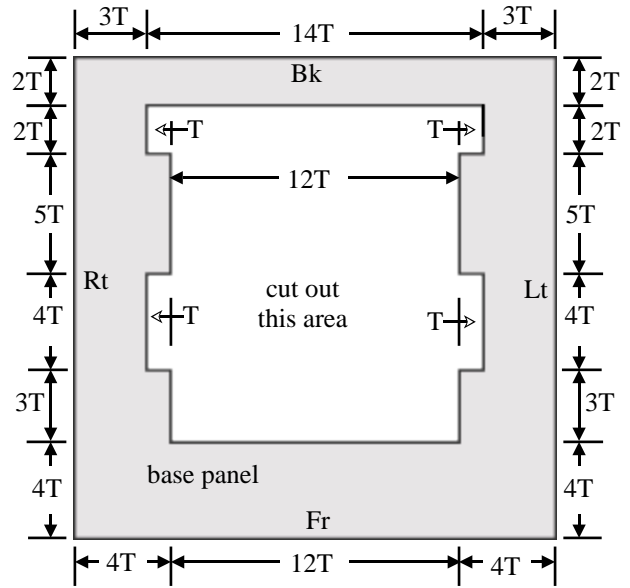

cut the inner 1 and 2 panels to this shape, and glue together:

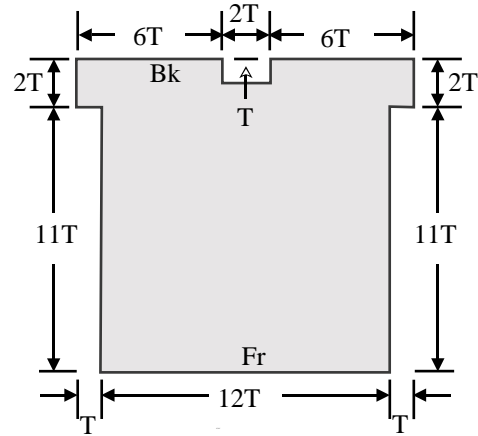

Assembly of the base panel

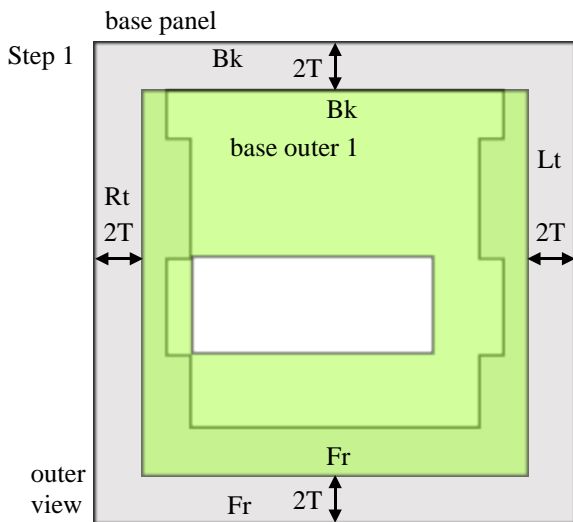

Lay the back panel down, and position the outer 1 panel centrally onto it, as shown.

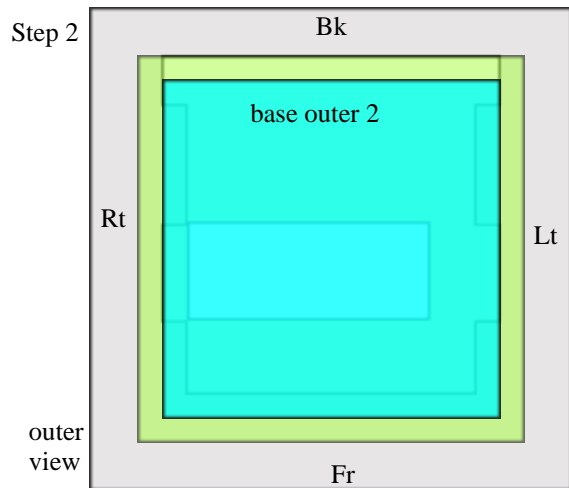

Position the outer 2 panel centrally onto the outer 1 panel. Using clear tape, secure the three pieces together.

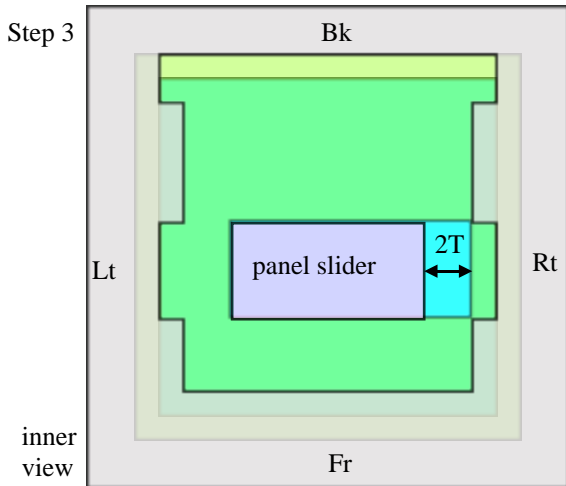

Turn the assembly over, back to front. Place the panel slider in the slot in the outer 1 panel, in the position shown. It will be resting on the inside face of the outer 2 panel. Make sure the panel slider can move towards to the right end a distance of 2T.

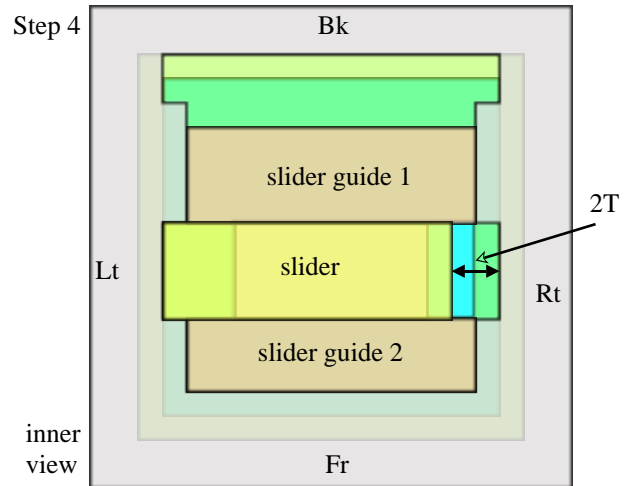

Place the slider guide 2, the slider and the slider guide 1 into the hole in the front panel, in the positions shown. Make sure the slider can move towards to the right end a distance of 2T.

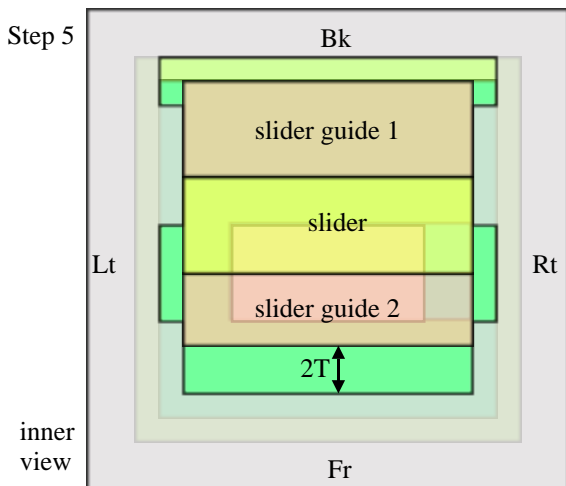

With the slider halfway, make sure that the two guides and slider can move towards the back end at least a distance of 2T.

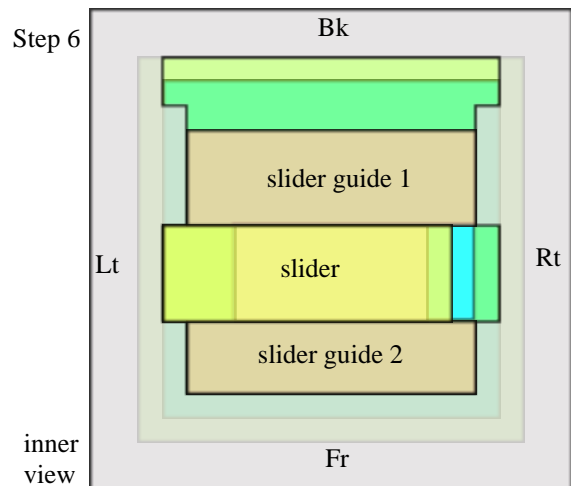

When the parts are moving properly, glue the two guides into their original positions. Take care not to glue either of the sliders.

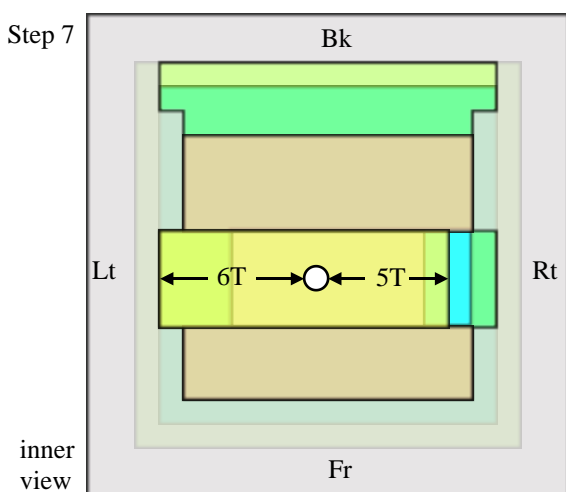

With the sliders and guides in their original positions, drill a hole, of diameter 1/8" (3mm) in the position shown, right through all the layers.

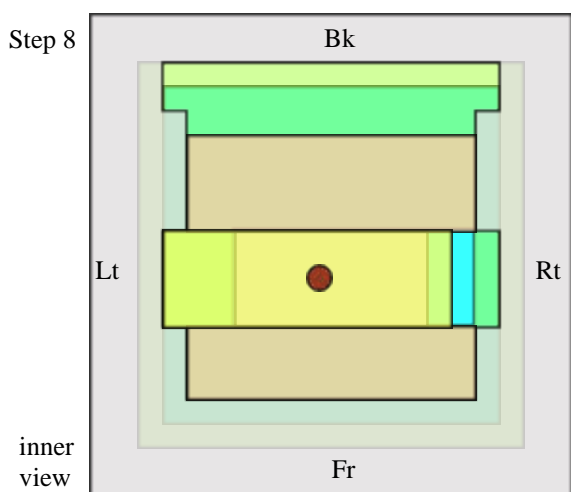

Insert the last dowel peg through the hole, making sure that the inner end of the dowel is flush with the slider. Note that the outer end of the dowel will not be in the centre of the outer 2 panel.

You may have noticed that although the moving parts are held together by the dowel peg, they're not actually held in place on the base panel.

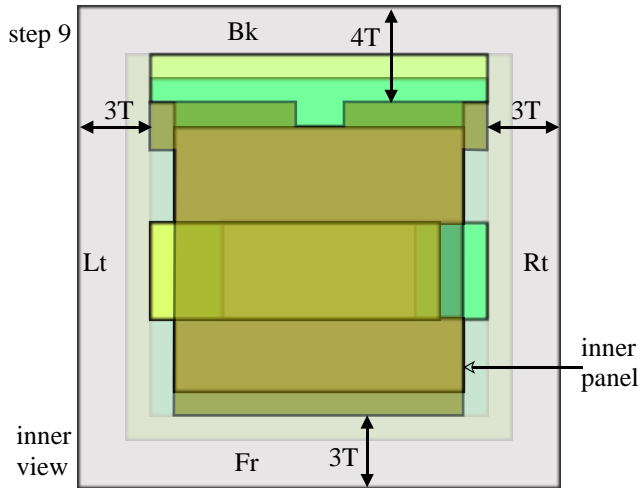

Place the base inner panel onto the base panel in the position shown.

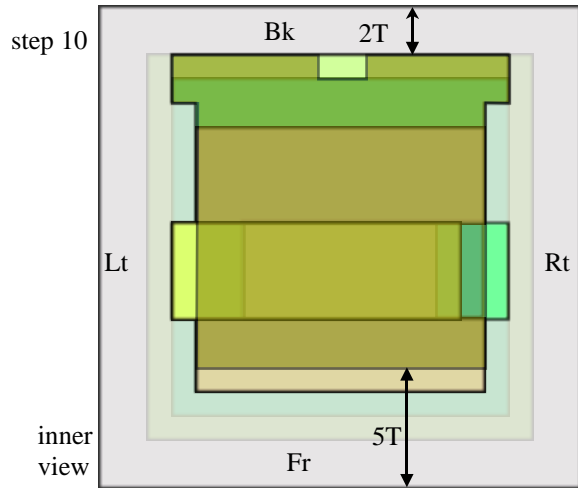

Move the inner panel towards the back end. After it has moved a distance of 2T, it should be free to pass through the hole in the base panel.

step 11

Remove the inner and base panels. If you want to colour the sides and panels, now is the time to do this, before the parts are glued together. Using the dowel pegs as a guide, glue the panel slider to the inside face of the outer 2 panel. Place the outer 1 panel on top of the outer 2 panel, and glue the slider to the inside face of the panel slider. Trim off the ends of the dowel peg. Insert this assembly back into the hole in the base panel.

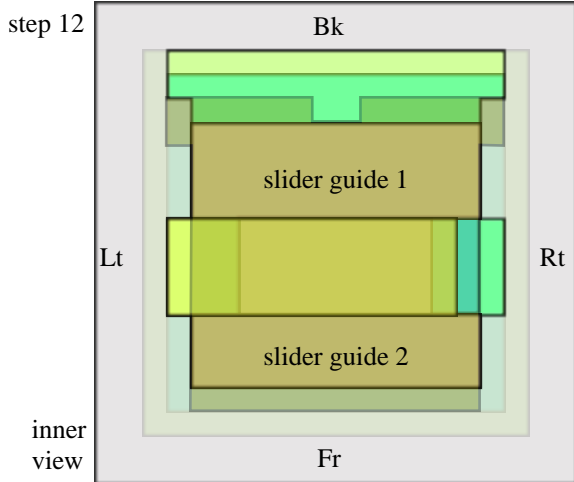
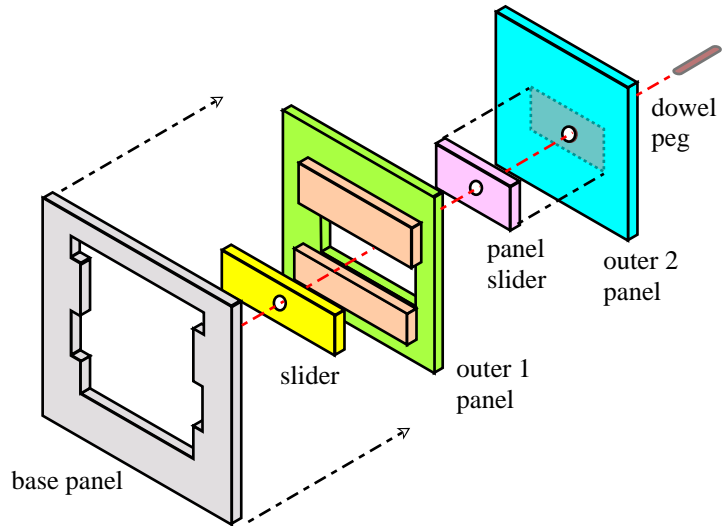

With the assembled outer panels in their original positions, glue the inner panel to both the **slider guides**. **DO NOT GLUE TO THE SLIDER.**

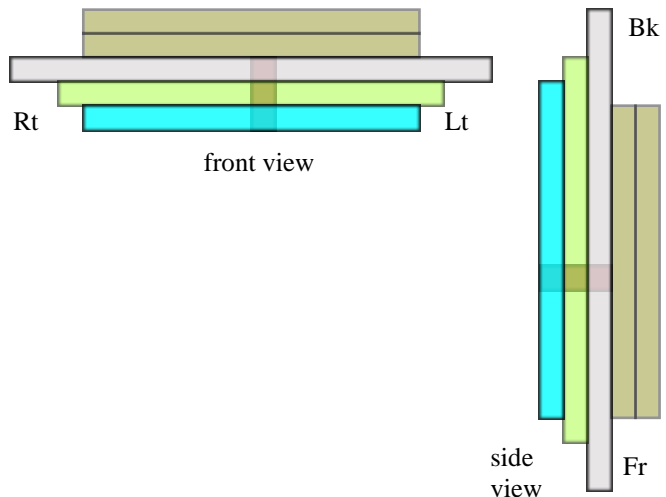

To test the panels, we'll have to go through the opening sequence, starting with the three already-assembled panels. Move the top outer 2 towards the right, just halfway. Now move both the outer panels towards the back, again, just halfway. Move the left outer 2 panel towards the back halfway, and both the outer panels upwards, again, just halfway. Move the front outer 2 panel upwards halfway, and both the outer panels towards the left, as far as they will go. The reason for the halfway movements?

If the top outer 2 panel is moved too far, both the top outer panels will be locked, and the front panel outer 2 cannot move upwards. If both the top outer panels are moved too far towards the back, the back outer 2 panel cannot be moved upwards.

If the left outer 2 is moved too far towards the back, the tongue on the inner 1 panel will engage in the notch in the back inner 1 panel, and again, the back outer 2 panel cannot be moved upwards. The rest of the opening sequence will still work until you get to the back panel. Because it's locked, the box cannot be opened.

If both the left outer panels are moved upwards too far, the tongue on the front end of the inner 1 panel will be out of alignment with the notch in the left end of the front inner 1 panel, and stop it moving far enough to the left, to release the right panel.

When the first three panels are working, it's best to glue the moving parts together.

Work on one side at a time, and don't forget- if you want to colour the sides and panels, now is the time, before the parts are glued together. Remove the dowel peg, and take off the outer and inner panels.

Using the dowel peg as a guide, glue the panel slider to the inside face of the outer 2 panel. Place the outer 1 panel on top of the outer 2 panel and glue the slider to the inside face of the panel slider.

Insert this assembly back into the side panel, and glue the inner 1 panel to the inside face of the **slider, and NOT the guides.**

Unlike the base panel, the inner panels on the other five sides can move in two directions, because they are connected to the sliders, which move in two directions. The dowel peg should ensure that all these pieces fit together correctly.

If there is an inner panel 2, glue this onto the inside face of the inner 1 panel.

Trim off the ends of the dowel peg.

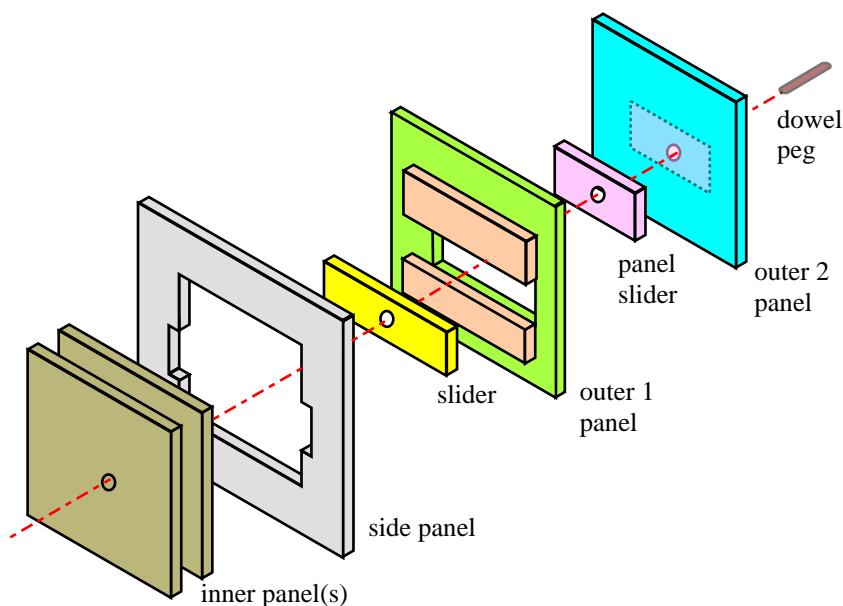

Hold the right panel in place against the three panels. Move the right outer 2 panel upwards halfway, and move both outer panels towards the front, as far as they will go.

Hold the back panel against the back of the box, and move the back outer 2 panel upwards, and both the outer panels towards the right panel.

When these two panels are working correctly, glue the working parts together in the same way as the first three panels. If you're going to colour the sides and panels, do it before gluing the parts back together.

Glue the back panel in place on the box, leaving the right panel off for the moment.

Hold the base panel against the bottom of the box, and move the back inner panels towards the right. Move the base outer 2 panel towards the right halfway, and both outer panels towards the back. When they have moved a distance of 2T, the moving parts assembly should pull out of the hole in the base panel.

With the box working properly, glue the right panel in place, and finally, glue the base panel onto the box.

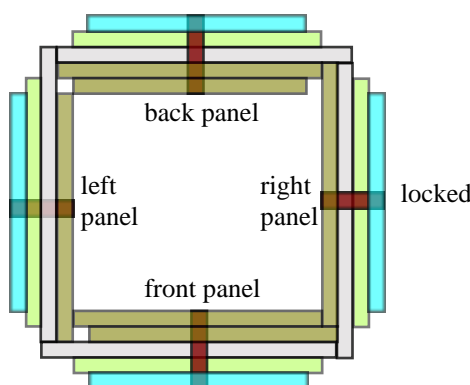

In these two views from the top, the top panel has been removed to show how the four side panels appear when the box is locked, and when open.

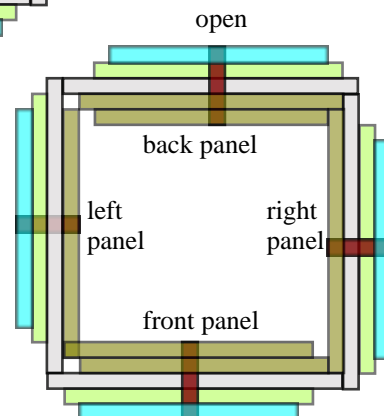

I used photographic dyes to colour the sides red, and the sliding panels green, in keeping with the original Chinese Torture plans. I did this before finally gluing the moving parts together. To hide the ends of the dowel pegs, I printed out some dragon motifs, and glued them to the outer panels. You can of course, put anything you like on the panels.

The dragon picture shown here should print out at 1-3/4" by 1-3/4", which is the size of the outer panels, if the box was made from 1/8" wood.

There's only one picture included here to keep the size of this file down, but you can get all six by downloading the "Chinese Torture Patterns" from the Free Patterns section on the web site.

The opening sequence is on the next page, to save you having to look back through the plans...



Make some T gauges

Cut twenty pieces of your wood, of thickness **T**, at about 1" x 1/2".

Glue ten together, then four, then three, then two. These five gauges will give you any size from **T** to **20T**. Measure and mark the wood with these T-gauges, **not with a ruler.**

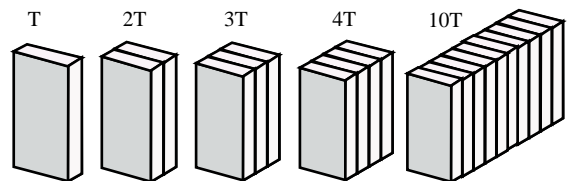

What is a T-Plan?

A T-Plan is a way of showing the dimensions of the parts, which uses the thickness of the wood you are using, rather than an absolute measurement. For instance, if you're using wood which is supposed to be 1/8" thick, and you have to cut a piece 1-1/2" long, and that length includes the thickness of two pieces of wood, then it should be 1-1/4" plus 1/4". If your wood was exactly 1/8" thick, then that measurement would be correct. If the wood was slightly thicker, then the 1-1/2" would be short. If we call the wood thickness "T", then the correct length should be 1-1/4" plus 2 times T (or simply 1-1/4"+2T). Then your piece would be correct length, no matter what the thickness of the plywood actually is.

These plans are free.

If you sell or give away this puzzle, please mention where the plans came from.

© Bruce Viney. March, 2010

If there are any mistakes in these plans, please let me know so that I can (hopefully) correct them.

Get more plans and solutions at **Homemade Puzzles.**

Web address: www.homemadepuzzles.co.uk

E-mail: bruce@homemadepuzzles.co.uk

Chinese Torture Solution

First, identify the sides: hold the box as in fig. 1. One side shows all four edges, and the opposite side is the same. One is the top, the other is the base. To identify which is which, the small panel on both sides can move, but only the larger panel on the top can move-the larger panel on the base cannot move yet.

The other four sides are overlapped at one end.

The small panels can move about 1/4" on all the sides except the back, which can only move 1/8".

The larger panels on all sides can move 1/8" or 1/4".

Now follow the figures below, making sure to hold the box the right way. Start with the top.

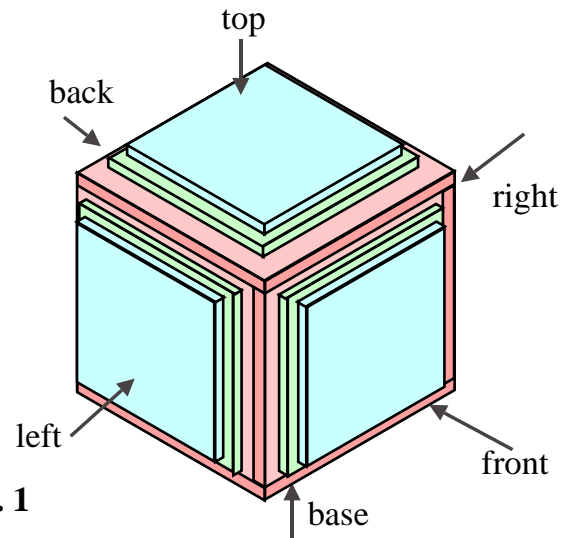

Fig. 1

Note: when you see "halfway", it means don't move that piece as far as it will go, only halfway.

The small outer panels can move independently of the larger panels, but when the larger panels move, they take the smaller panel with them.

1. Move the top smaller panel halfway to the right.
2. Move the top larger panel halfway towards the back.
3. Move the left smaller panel halfway towards the back.
4. Move the left larger panel halfway towards the top.
5. Move the front smaller panel halfway towards the top.
6. Move the front larger panel all the way towards the left.
7. Move the right smaller panel halfway towards the top.
8. Move the right larger panel all the way towards the front.
9. Move the back small panel all the way towards the top.
10. Move the back larger panel all the way towards the right.
11. Move the base smaller panel halfway towards the right.
12. Move the base larger panel all the way towards the back.
13. Pull the larger panel outwards: box open.

Some things to remember.

If you move the right panel first, you cannot make the top panel's first move!

If you move the back panel first, you cannot make the top panel's second move!

If you move the top panel too far on it's first move, you cannot make the front panel's first move!

If you move the top panel too far on it's second move, you cannot make the back panel's first move!

If you move the left panel too far on it's first move, you cannot make the backpanel's first move!

If you move the left panel too far on it's second move, you cannot make the front panel's second move!

All of these moves will prevent you from removing the panel from the base.

This is the only panel that can be removed.