

Homemade Puzzles

Blade Clamp Modification

For the Ferm, Brunel and Perform Scrollsaws.

If you use one of these scrollsaws, you'll know how difficult it is to get a pinless blade in place, using the little clamps supplied.

When the clamps are in place, the top clamp is about 1/2" below the top jaw, and it takes a lot of effort to force the clamp in place.

Because it's so tight, the saw vibrates and makes a lot more noise!

This little gadget makes changing a clamped blade as easy as changing a normal blade.

Which means the saw is quieter, with a lot less vibration.

I've used this on my Ferm scrollsaw, and it works!

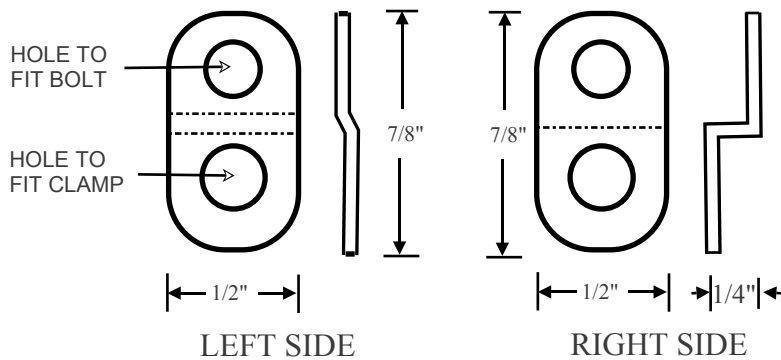

All you need:

Two pieces of steel or aluminium:

one at 1/2" x 7/8" x 1/16"

one at 1/2" x 1-1/8" x 1/16"

One 10mm nut and bolt, 1" long.

A metal sleeve to fit bolt.

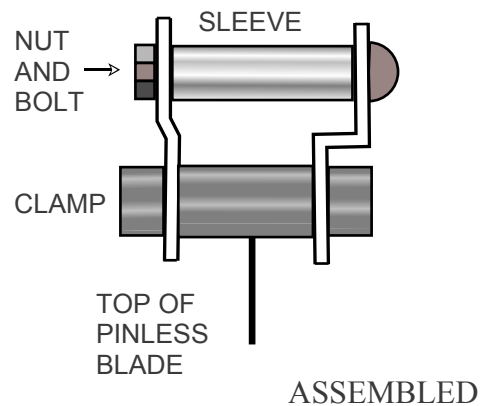

The bottom of the blade is held in the clamp which came with the saw, and is held in place as normal.

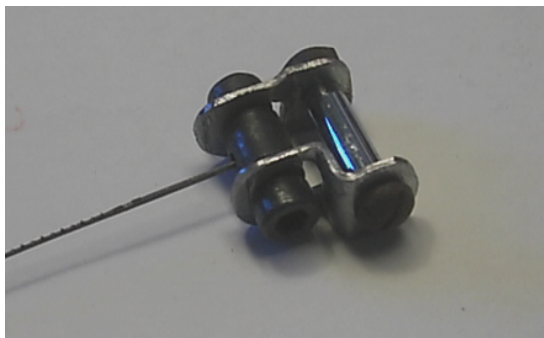

Mod fixed to clamp

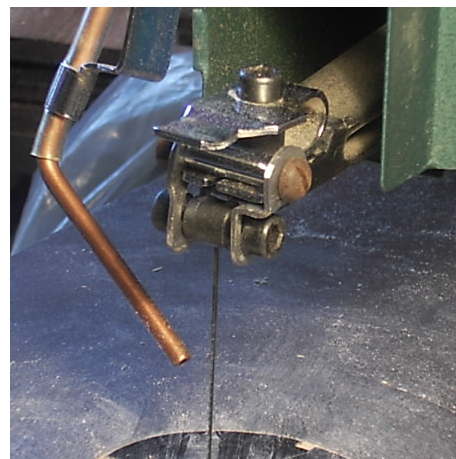

In place on the saw

These hints and tips are provided free.
It's up to you whether to use them or not.
If you make a mess of things, I'm not responsible!

© Bruce Viney 2007

Get more plans and solutions at **Homemade Puzzles.**

Web address: www.homemadepuzzles.co.uk

E-mail: bruce@homemadepuzzles.co.uk