

Black Nightmare Plans

Homemade puzzles

First, an explanation of the box. There are four sliding sides that can be removed, these are the top, left, right and base. The front and back panels hold a smaller panel, split in half. These half-panels slide sideways and control the other sliding sides. Whatever moves you make on the front, you must make the same moves on the back, in order to move the other sides. Eventually, you can remove the top, base, left and right panels.

These dimensions shown are based on the box being constructed from 4mm and 6mm plywood. If you use a different size wood, you will have to adjust your measurements. All sizes shown are in millimetres.



Start with the inner box. Pieces required:
two at 6 x 44 x 56: the sides
six at 4 x 8 x 48: the strips
one at 4 x 48 x 56: the base

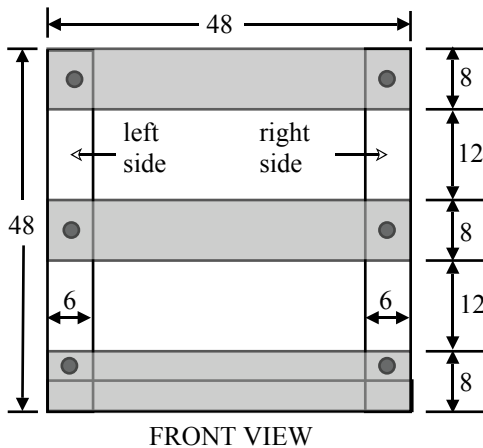

pin and glue the six strips to the ends of the 6mm ply

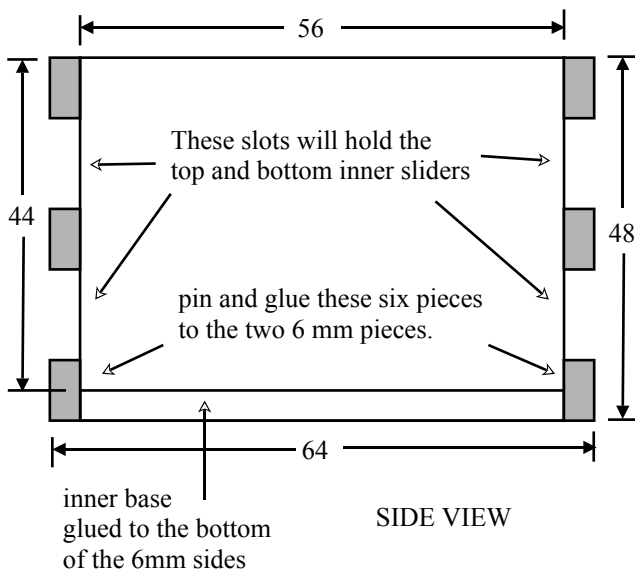

Back and front panels. Cut two to these dimensions. Use 4mm thick plywood.

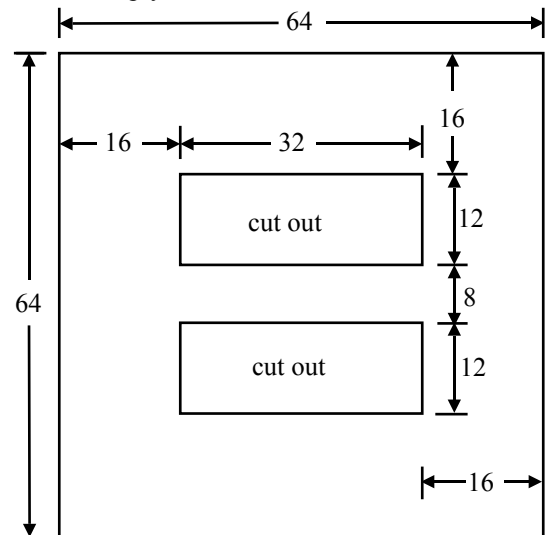

The runners for the four removable sides are made from 4mm square strips. These runners are the black shapes shown below. Cut to the lengths shown, and glue to the back panel.

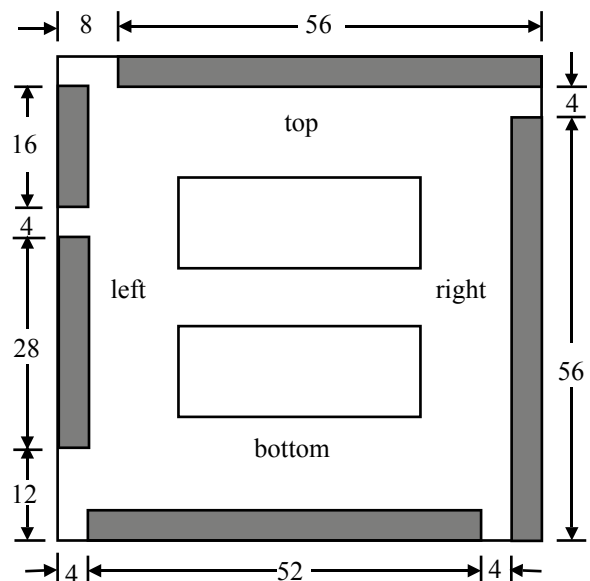

This is the inside face of the **back panel**. The inside face of the front panel is a **mirror image** of this. All the runners will be reversed, left to right, on the inside face of the front panel.

Cut the **two inner top sliders**, and **two inner bottom sliders** from 4mm plywood.

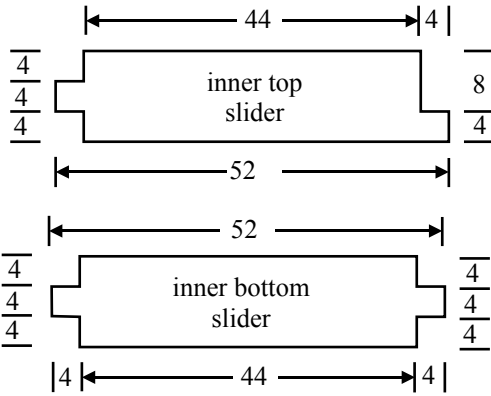

Cut the two **middle top sliders**, and two **middle bottom sliders** from 4mm plywood.

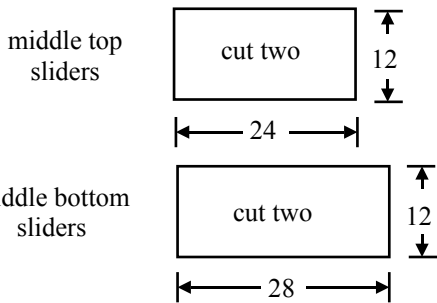

From 4 mm ply, cut **four** pieces, 24 x 48 mm. Two of these are the **top outer sliders**, the other two are the **bottom outer sliders**.

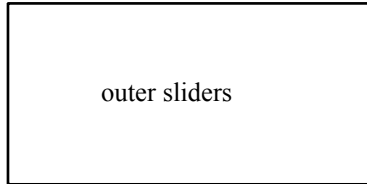

Assembly of the inner box.
Start with the pieces for the **back panel**.

Lay two **outer sliders** on a firm surface, and secure them so that they cannot move. Position the back panel in place, with the runners facing you, so that the outer sliders, which form a square, are exactly in the centre.

Do not glue anything yet.

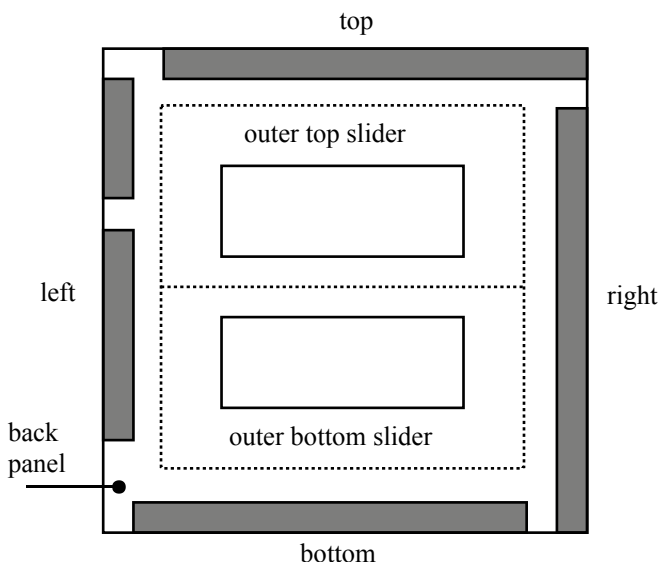

Position a **middle top slider** and a **middle bottom slider** into the slots in the back panel, and glue to the inside faces of the **outer sliders**. Notice that the pieces are not the same length.

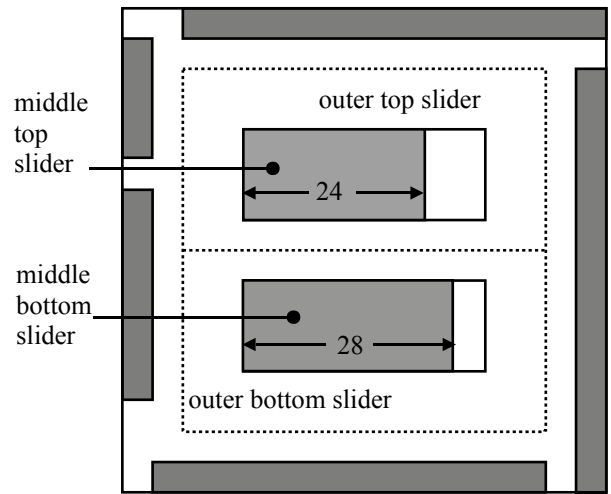

Position an **inner top slider** and an **inner bottom slider**, and glue to the inside faces of the **middle sliders**. Notice that the left tongue on the top slider is engaged in the notch in the left runner.

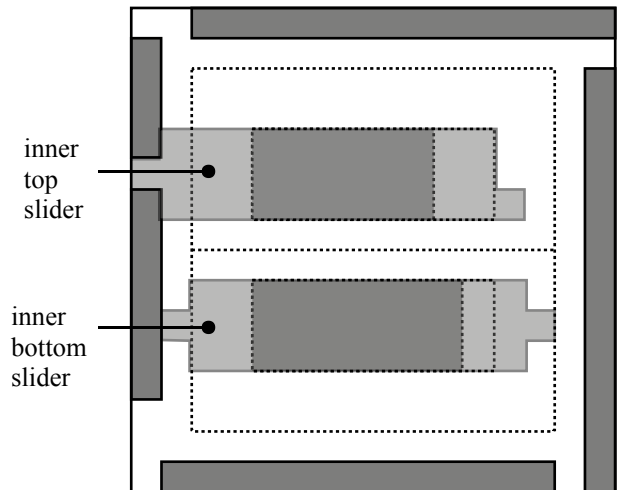

Position the inner box in place, exactly in the centre, and glue to the **inside face of the back panel**. Be sure to only apply glue to the **three strips** on the back of the box- the sliders **must** be free to move.

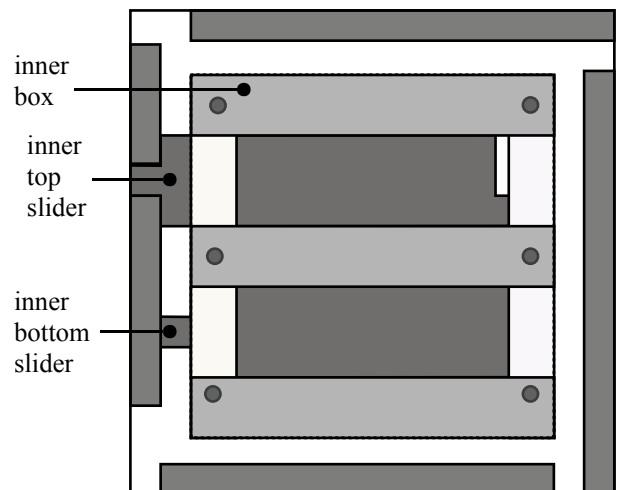

The front panel assembly is the same as the back, but is reversed left to right:

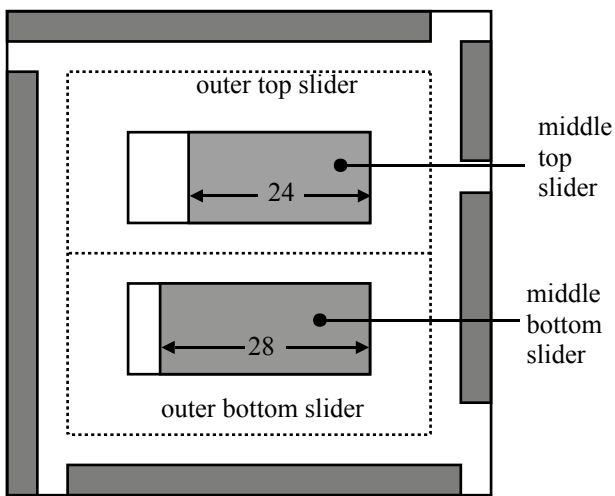
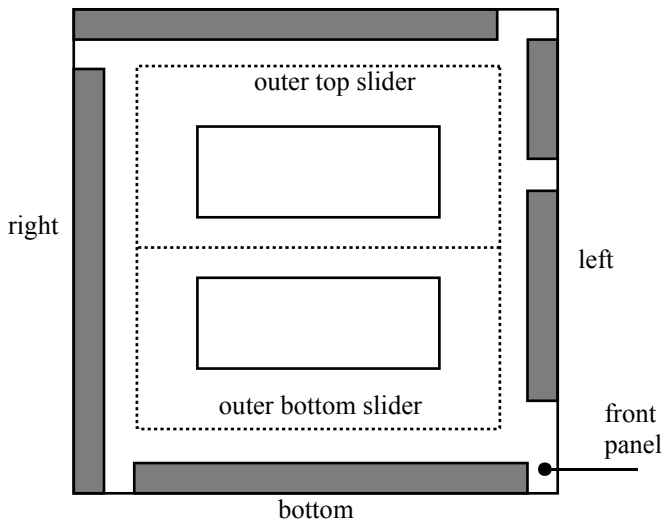

The completed inner box with front and back panels in place, should look like this:

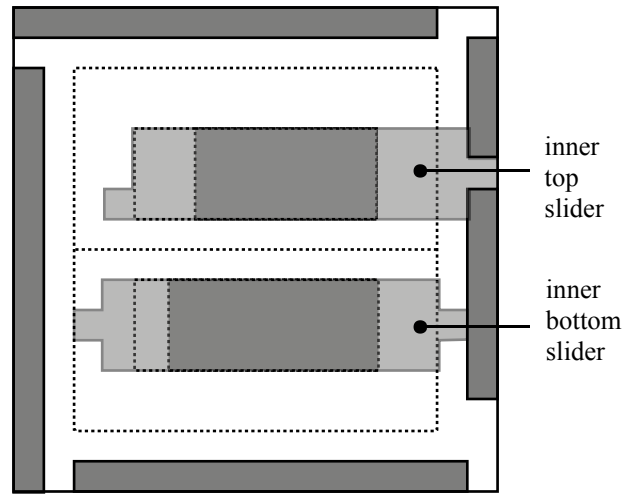
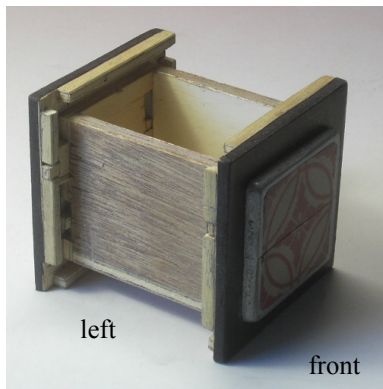

This time, when you glue the inner box in place, it will have the back panel attached. This view of the inside of the front panel doesn't show the back panel.

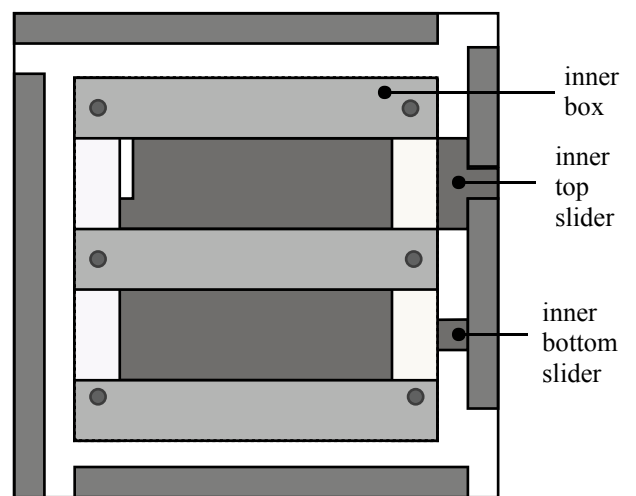

Bottom panel: Pieces required: from 4mm plywood.

one at 64 x 48 (A): one at 56 x 56 (B):
one at 72 x 64 (C): one at 48 x 48 (D).

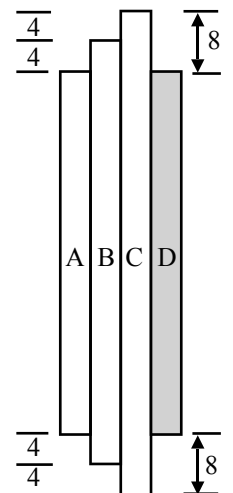
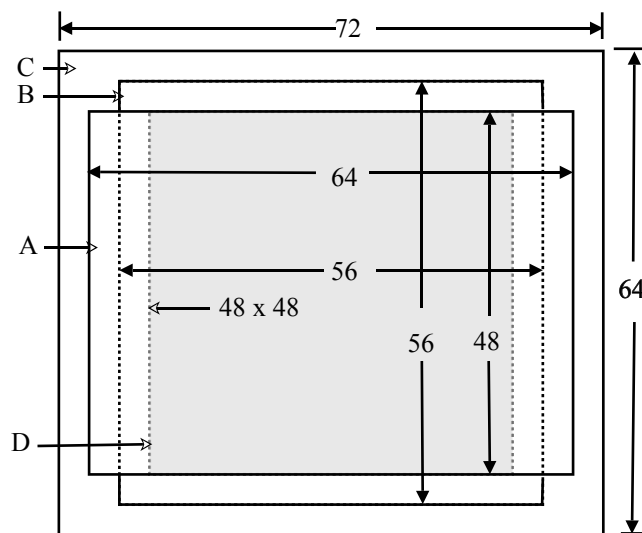

east-west view

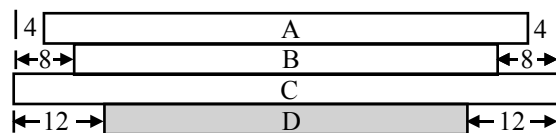

south-north view

VIEWS ALONG THE PANEL

Lay the 48 x 48 piece down, making sure it can't move, and glue panels C, B and A in place, as in these diagrams.

inner piece (A) middle piece (B)
outer piece (C) decorative panel (D)

Top panel:

Pieces required: from 4mm plywood.

- one at 48 x 48 (D)
- one at 72 x 64 (C)
- one at 56 x 52 (B)
- one at 64 x 52 (A)
- one at 4 x 4 x 56 (E)

Lay the 48 x 48 piece down, making sure it can't move, and glue panels C, B, E and A in place, as in this diagram:

- inner piece (A) middle piece (B)
- outer piece (C) decorative panel (D)

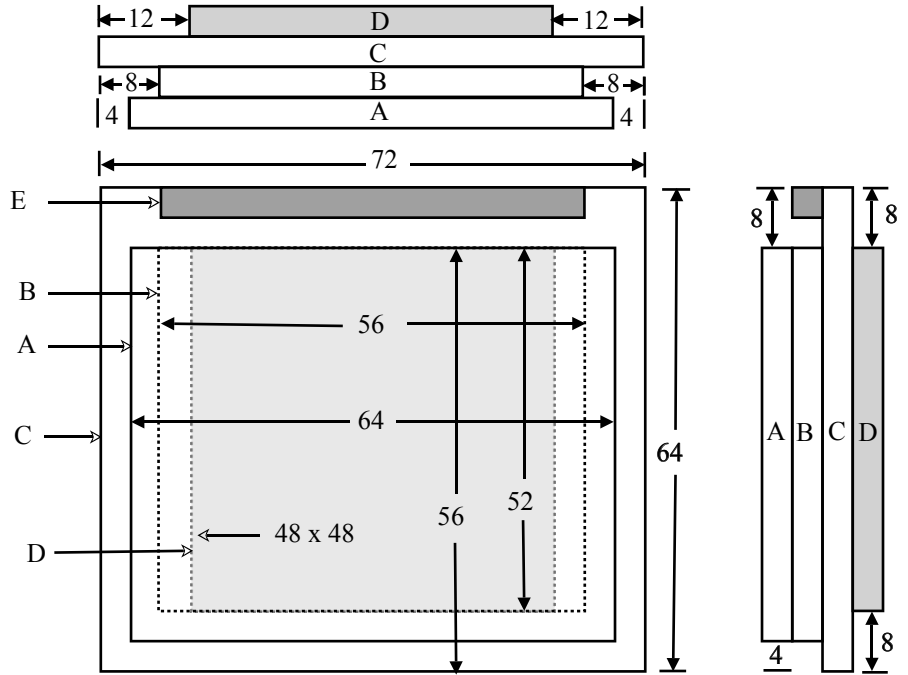

Left panel:

Pieces required: from 4mm plywood.

- one at 64 x 52 (A): one at 56 x 52 (B)
- one at 72 x 72 (C): one at 48 x 48 (D)

Lay the 48 x 48 piece down, making sure it can't move, and glue panels B and C in place, as in these diagrams.

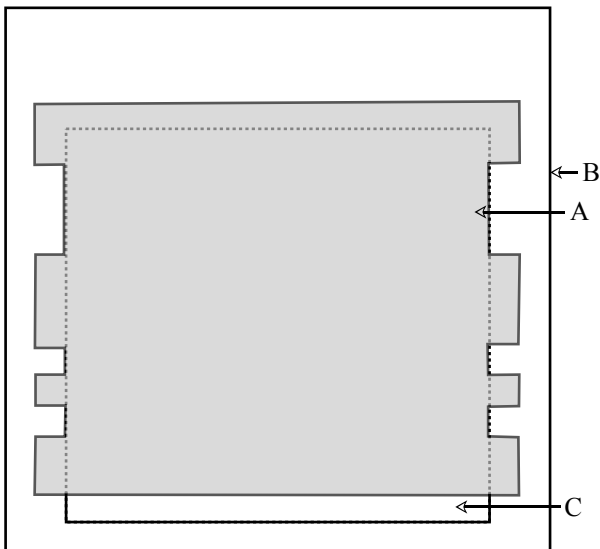
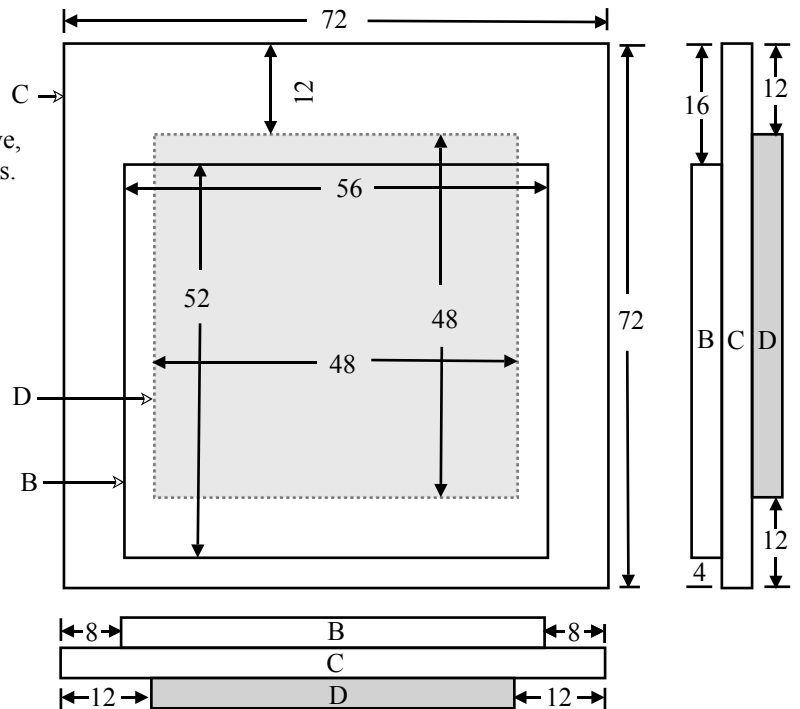
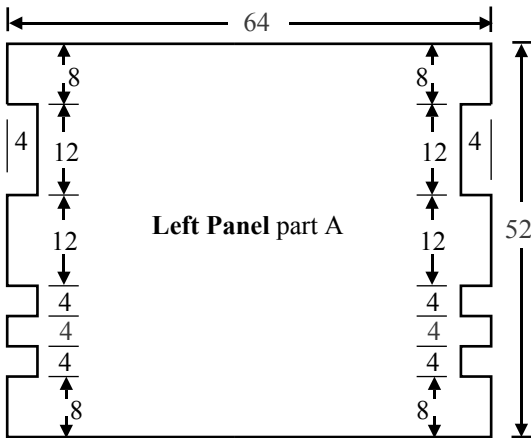

Glue the left panel part A in place.

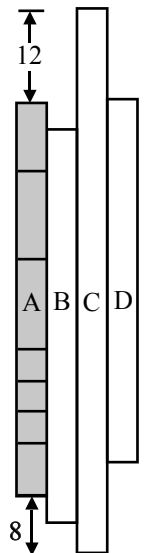
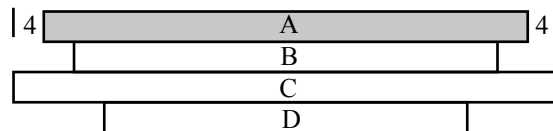

Right panel:

Pieces required: from 4mm plywood.
 one at 64 x 40 (A): one at 56 x 64 (B)
 one at 72 x 72 (C): one at 48 x 48 (D)
 one at 4 x 4 x 56 (E)

Lay the 48 x 48 piece down, making sure it can't move, and glue panels B,C and E in place, as in these diagrams.

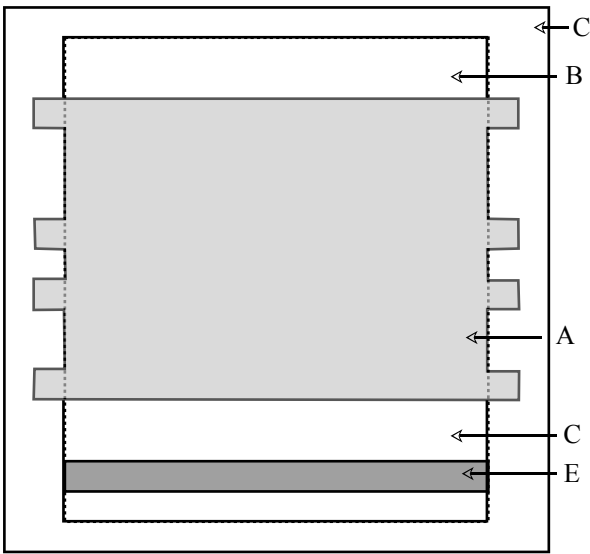
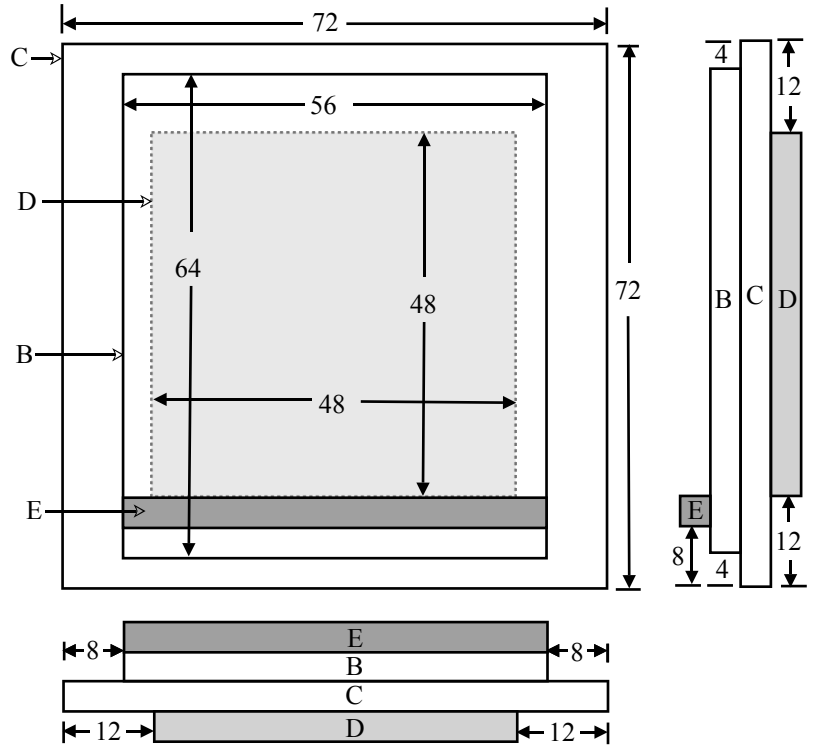
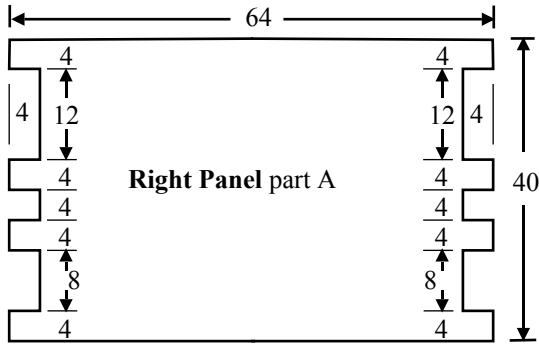

Glue the **right panel part A** in place.

In this view along the panel, piece E is not shown, to show the position of Part A.

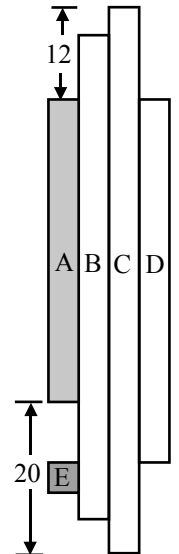
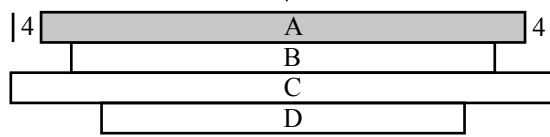

That's all the pieces completed.
 Next step is to assemble the box.

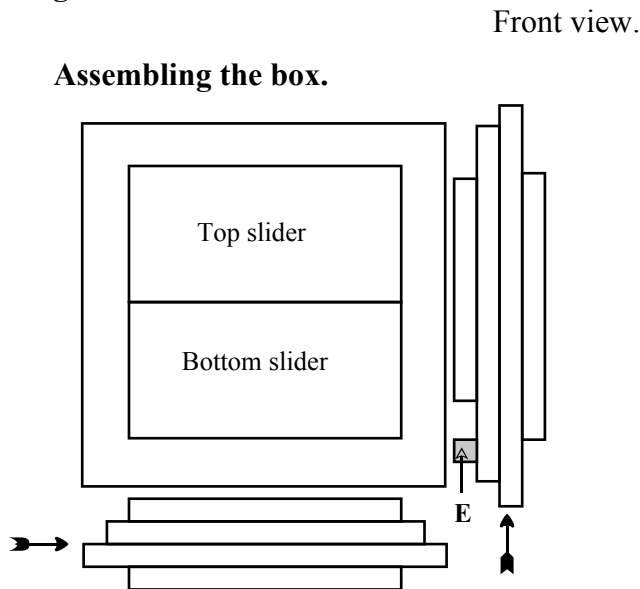

Looking at the front, the right panel slides up from the base, making sure the small bar (E) is at the bottom. The base, which can be either way round, slides in from the left.

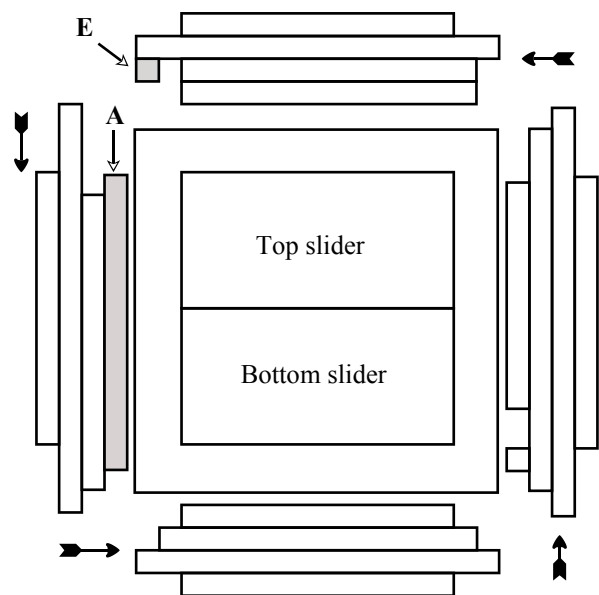

The left panel slides down from the top. make sure part (A) is uppermost. The top slides in from the right, making sure the small bar (E) is on the left. When the left panel is uppermost, part (A) will engage this small bar.

Of course, to get these panels in place, you have to move the front and back sliders from side to side, to allow the left and/or/right panels to move up/down. That's the fun of the puzzle! **If you get stuck, download the solution.**

Suggested finish: I glued thin black paper to the front and back panels, and used artist's spray fixative to protect the paper. After the four sliding panels were made, and before fitting into place, I did the same for them. This artist's fixative protects against dampness. The small outer panels were painted with silver paint. A small Celtic pattern (printed from the computer) glued on, and again sprayed with the fixative. Then the whole box given a coat of spray varnish.

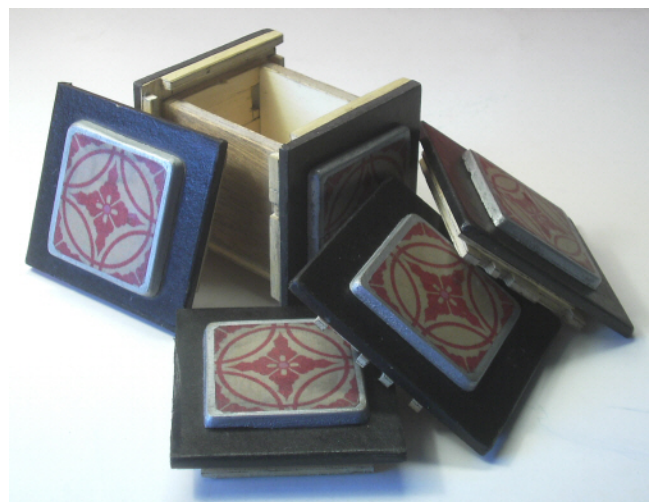

Enjoy your puzzle!

Plans amended July 10th, 2008.

(The assembly position of both middle bottom sliders.)

Plans amended August 2nd, 2008.

(Size of E on page 4, lettering of parts on pages 4 and 5.)

Plans amended November, 2008.

(Total length of the inner box is 64, not 72. page 1)

These plans are free,
If you sell or give away this puzzle,
please mention where the plans came from.

© Bruce Viney. January, 2008

Get more plans and solutions at Homemade Puzzles.

Web address: www.homemadepuzzles.co.uk

E-mail: bruce@homemadepuzzles.co.uk